

Alaska PG3 Chip Seal Inspector Training

Intro, Pavement Preservation, Chip Seal, Demo Day

Rex W. Eberly

National Center Pavement Preservation



MICHIGAN STATE
UNIVERSITY

**Alaska DOT
PG3 Pooled Fund Study
Chip Seal Inspector Training
Agenda**

8:30 am – Introduction

- Instructor –
- PG3 Overview
- Class Preview

8:45 am – Pavement Preservation Basics

- Why Pavement Preservation
- How does Chip Seal fit into Preservation / Preservation Maintenance

9:15 am – Chip Seal Best Practices

- Overview
- Equipment
 - Inspection
 - Calibration
- Materials
- Application

10:45 am – What to Expect on Demonstration Day

- Contractor Role
- Inspector Role
- NCPP / Volunteer Role

11:15 am – Questions and Comments

11:30 am - Adjourn





Transportation Pooled Fund-5(522), PG3

Joel Uring, Pavement Preservation Engineer
Office of Materials and Road Research

Southeast Pavement Preservation Partnership Conference
March 18, 2025



MnDOT/NCAT Preservation Group Studies - History:

- **NCAT - Lee Road 159**

Pavement Preservation Study (2012-Present)

- **TPF-5(267) PG1**

Accelerated Performance Testing for the NCAT Pavement Test Track (2015-2018).

- **Alabama – Lee Road 159 & US 280**
- **Minnesota – Mille Lacs County CSAH 8 & US 169**

- **TPF-5(375) PG2**

National Partnership to Determine the Life Extending Benefits of Pavement Preservation Techniques (2018-23).

- **70th Street NE – Rehabilitation & Thinlay Treatments**

- **TPF-5(522) PG3**

National Partnership to Improve the Quality of Pavement Preservation Treatment Construction and Data Collection Practices (2024-2028).

MnDOT / NCAT Partnership

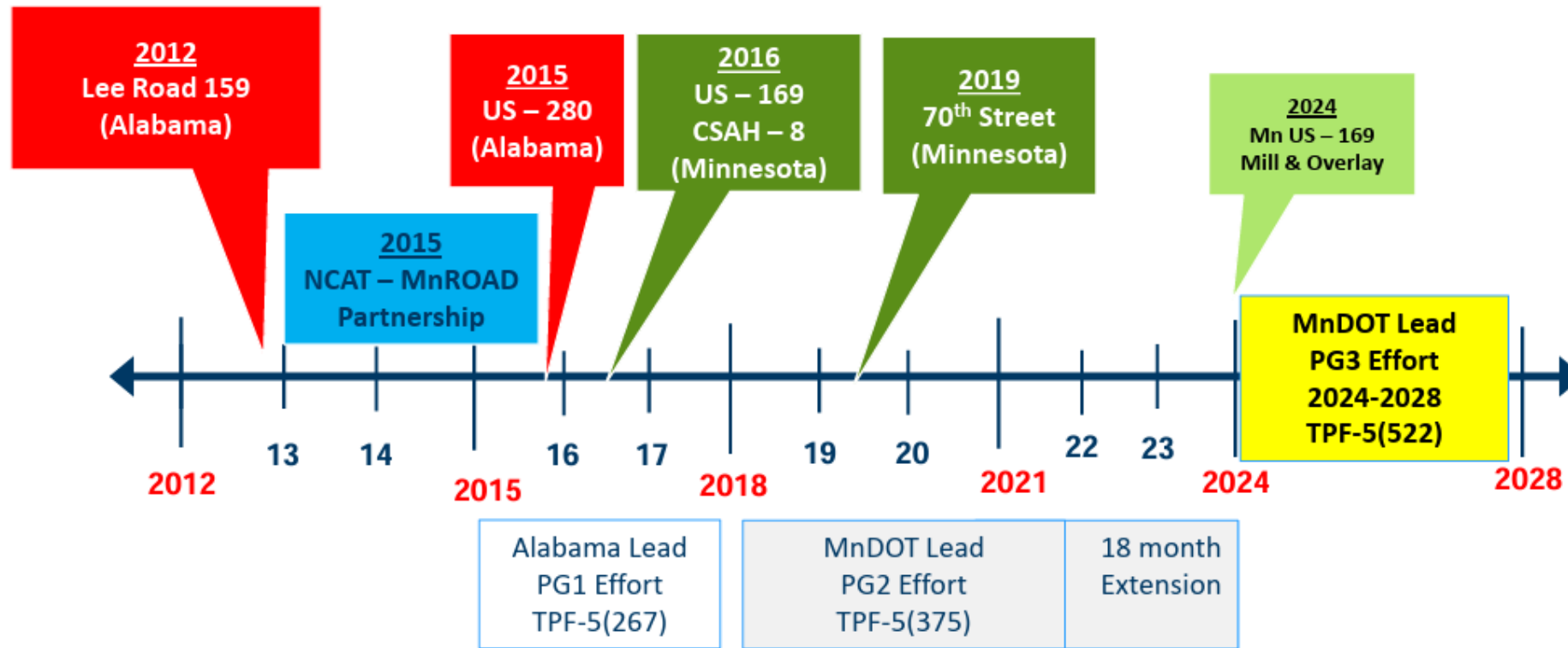

Pavement Preservation Future

Improving the Quality of Pavement Preservation Treatment Construction and Data Collection Practices

Phase III or PG3 (Jan 2024-Dec 2028)

- **TPF-5 (522) – PG3**
- **Focus on State Implementation of Pavement Preservation Treatments**
 - Specification review
 - Preconstruction technical support & training (virtual)
 - Construction support (on-site)
 - Performance monitoring
- **Contracts with both NCPP and NCAT to support the effort**
- **Technical Advisory Panel Led (Agencies)**
 - Guidance from NCPP, NCAT, FP2, FHWA
 - Sponsor meetings
 - Two in-person/year
 - Two virtual/year
- **Pooled Fund Started January 2024 extending to December 2028**
- **Web Page: <https://pg3study.org>**

State	Nominated Project	Under Consideration	Nomination Date	Expected Construction Year	Construction Notes	Virtual Training Scheduled	Spec Review	Secondary Project
Alabama		AL will be submitting the projects May-June, will have idea which one they want to nominate then. 2026.						
Alaska	Thin HMA	CO struggling to find a project. Moving towards worst first, only 1 chip seal job this year. Considering spray applied rejuvenator. 2026.	7/10/2024	2026			Chip Seal 2/28 to FP2	Chip Seal - 2026
Colorado								
Delaware	Micro Surface		3/17/2025	2025			Comments to Delaware 4/9/25	
Idaho	RAP Chip Seal		12/12/2024	2025	Running construction on July 28-29. 5/27 setup ready to process RAP. Prime contractor is Western Construction, sub is Koeffler Inc, who also fractionated the RAP.	7/11/2025. Rex will lead.	RAP provision to FP2 4/2/25. Our initial comments to Adrienne 4/4.	
Illinois		Considered polymer modified slurry, but District had already released the project. Did not get a hybrid, may consider updating spec and doing this again. Southern Illinois. Could still happen 2025 late or early 2026. Share special provision.						
Maryland		Looking at scrub seal. Will have spec soon for us to review, looking to construct 2026.						
Michigan	Chip Seal/SAMI	Ran on starting first of May.	2/10/2025	2025	Project awarded as of 5/19, getting more details. As of now thinking to waive off on this project, not ready for PO3. Thinking will go with the high friction micro.		High Friction Micro 2/28 to FP2. Our comments back to MDOT 4/22.	High Friction Micro
Minnesota	Cape Seal (Scrub+Micro)		1/30/2025	2025	Awarded to Assoc Construction. They do both scrub and micro.	July 29-1 EDT. Rex will lead and Mark will participate.		2 Feb
Mississippi	Cape Seal (Scrub+Micro)		11/14/2024	2025	Notice Proceed 4/10/25 Pre-Con schedule don 4/2/25 started scrub on test cell Wednesday, June 4. Contractor constructed the micro test cell 6/16/25. Micro for job complete 6/26/25. TL Wallace is prime.	5/8/2025; 8:00 - Noon, Hattiesburg District Office	Spec review comments sent 12/13/24. scrub mix design rec'd 5-27-2025, in MAU	
New Mexico		Looking at RAP chip seal, northern part of state. Looking to start in 2026. Not sure yet if will be contacted or done within-house.						
New York		Behind on getting something to be evaluated. 2026 would be the earliest.						
North Carolina	Spray Applied Rejuvenator	Advertise today, lets April 18, 2.1 miles. Completion May 2026, but work should happen this year.		2025	Awarded 5/2/25 to Pavement Technology Inc. Looking at Late-July or Early August construction.	June 12, 2025 9:00 EDT	10/19/24 example spec provided	
North Dakota		Highly modified micro surfacing, but getting some negative feedback. Still want to monitor test sections previously constructed. Project would be 2026.						
South Carolina		Scrub Seal, let as a chip seal looking to change part of it, if so will be 2025. If not will select another project for 2026.						
Texas		Will be nominating a CIR soon, will construct in 2026.						
Washington	Chip Seal with Rut Treatment		1/8/2025	2026				

Who is NCPP?

- ▶ The National Center for Pavement Preservation
 - NCPP was established by Michigan State University and FP2, Inc. to lead collaborative efforts among government, industry, and academia in the advancement of pavement preservation by advancing and improving pavement preservation practices through education, research and outreach.

What Does NCPP Do?

▶ Collaborate

- AASHTO
 - Preservation Management Partnerships
 - Emulsion Task Force (ETF)
- MnROAD, NCAT, PPRA

▶ Advance

- National Pavement Preservation Conference (NPPC)
- Research Projects
- Training and Education Survey

▶ Improve

- National Pavement Preservation Certification Program
- Agency and Industry Training

Pavement Preservation Is...

- ▶ “Programs and activities employing a network level, long-term strategy that enhances pavement performance by using an integrated, cost-effective set of practices that extend pavement life, improve safety and improve motorist satisfaction while saving public tax dollars”.
- The treatment must:
 - Address pavements while they are still in good condition
 - Reduce aging
 - Extend Pavement Life
 - Restore Serviceability**

Define the Definition

- **Network Level**
 - All Pavements (Urban, Rural, Airports)
 - Asphalt and Concrete
- **Long-Term Strategy**
 - Budgeted Expense
- **Integrated**
 - Department Wide
 - All Stakeholders
- **Cost-Effective**
 - Right Treatment, Right Road, Right Time
- **Improve Road User Satisfaction**

Why Develop a Preservation Mindset?

- ▶ **Budgets**
 - Few agencies can afford a strategy of Build It, Rehab It, Build it Again
- ▶ **Pavement Performance**
 - FHWA Performance Thresholds will be difficult to meet without Preservation.
- ▶ **Material Changes**
 - Pavements don't seem to be lasting as long. Preservation stretches the service life of your pavements
- ▶ **Sustainability**
 - Carbon Reduction Act
 - Environmental Product Declarations (EPD's)



Alaska Department of Transportation and Public Facilities Transportation
Carbon Reduction Strategy

A Five-Year Comprehensive Plan: 2024-2028

11/15/2023

Prepared for: Federal Highway Administration

THE BEST REASON IS – IT WORKS!



Why Don't We Just Mill and Fill Everything?



Construction Equipment Magazine.com

State Example #1 – Worst First / Overlay Heavy

The FY 2023 Highway Program approximately \$1.6 billion for roadway preservation activities.

The MDOT estimates for their FY 2023 Repair and Rebuild Roads program (roadway preservation) will include approximately: 1,111 lane miles of reconstruction and improvements, 821 lane miles of capital preventive maintenance, and 206 lane miles of freeway and non-freeway resurfacing.

$2138 \text{ L.M.} / 32,045 \text{ L.M} = 6.7\%$ of the network

$32,045 \text{ L.M} / 2138 \text{ L.M} = 15 \text{ Year Cycle}$

$1.6 \text{ Billion} / 2138 \text{ L.M} = \$ 748,363 / \text{LM}$

State Example #2 – Preservation Mindset

- ▶ Improved 7,102 miles of pavement in fiscal year 2023.
- ▶ Improvement includes Seal Coat, Micro surfacing, Thin Lift and Regular HMA Paving
- ▶ $7,102 \text{ miles} / 35,776 \text{ miles} = 20\%$ of the network or a 5-year cycle.
 - Mix of treatments
 - Seal Coat – 60%
 - Paving – 20%
 - Other – 20%

From Theory To Practice

- ▶ A Worst-First Rehabilitation Program Won't Save Your Network.
 - ▶ Deferring Preservation Maintenance does **NOT** save \$\$\$.
 - ▶ A balanced approach is best.
 - ▶ Use Planned, Lower Cost Treatments To Extend Remaining Service Life.
- 

PRESERVATION VS. PRESERVATION MAINTENANCE

▶ PRESERVATION

- GOAL IS TO PLACE A TREATMENT THAT PRESERVES THE SURFACE AND EXTENDS RSL (REMAINING SERVICE LIFE)
- TIME BASED
 - EARLY AND OFTEN
- ADD SERVICE LIFE
- GENERALLY, LESS EXPENSIVE TREATMENTS

▶ PRESERVATION MAINTENANCE

- GOAL IS TO REPAIR SURFACE DEFECTS, PRESERVE THE SURFACE AND EXTEND RSL (REMAINING SERVICE LIFE)
- TIME AND CONDITION BASED
 - PLACED AS EARLY AS POSSIBLE WHEN DEFECTS OCCUR.
- STOP THE DETERIORATION AND ADD SERVICE LIFE.
- MORE AGGRESSIVE PRESERVATION TREATMENTS
 - COMBINATION TREATMENTS

When Should We Not Use Thin Surface Treatments?

Structural Defects Vs. Functional Distress

- ▶ Chip Seal or Micro surfacing should **NOT** be placed on a Pavement with Structural Defects.
- ▶ A Structural Defect means either the Pavement or the Base has failed.
 - Pavement Failure
 - Stripping – the asphalt no longer adheres to the rock
 - Potholes – if not repaired
 - Rutting – if continuing to rut
 - Longitudinal and Transverse Cracking – Heavy
 - Base Failure
 - Alligator Cracking – the base or sub-base has failed and no longer supports traffic loading.
 - Water and / or fines pumping – the base is failing, and Alligator Cracks will soon appear
- ▶ Chip Seal or Micro surfacing can be used to treat **moderate** Functional Distresses.
- ▶ A Functional Defect, if not treated may become a Structural Defect.
- ▶ A Functional Defect is often caused by environmental or traffic conditions.
 - Rutting – if rutting has stopped
 - Bleeding
 - Longitudinal and Transverse Cracks – Light to Moderate
 - Polishing
 - Raveling

Structural

Functional (Surface)

WWW.RoadResource.org

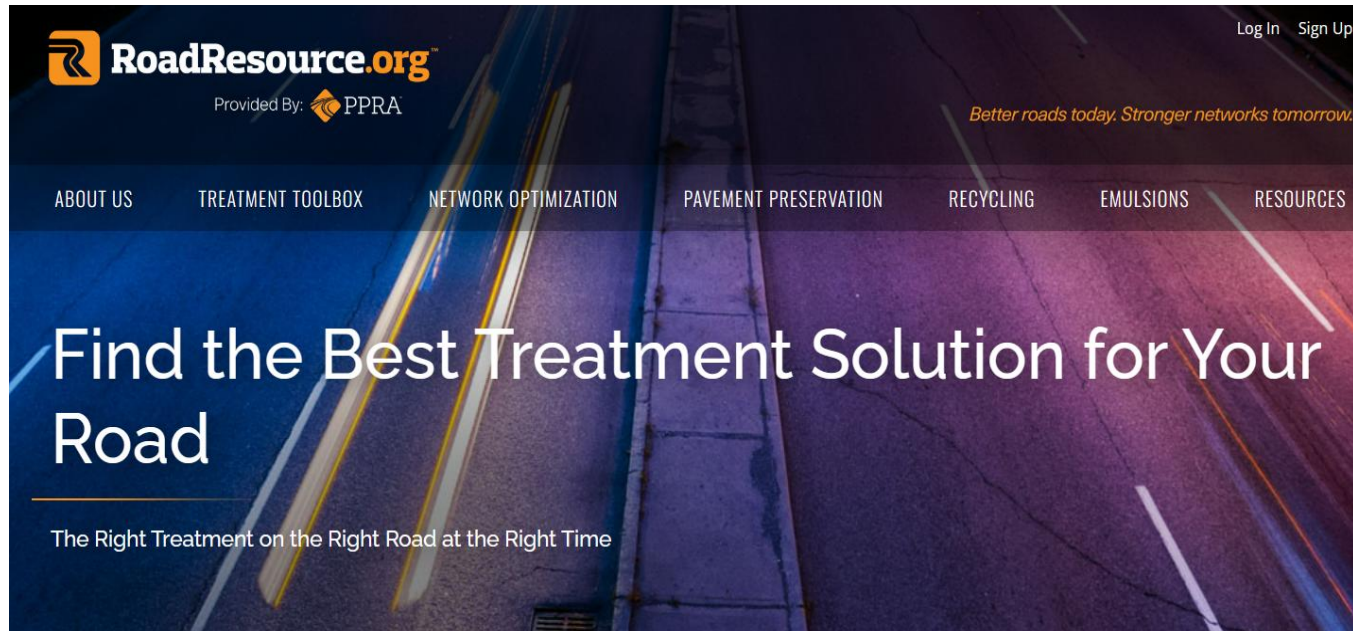

The image shows the homepage of the RoadResource.org website. The background is a dark, artistic photograph of a road at night with light trails from traffic. The website header includes the logo for RoadResource.org, which is a stylized 'R' in a square, followed by the text 'RoadResource.org'. Below the logo, it says 'Provided By: PPRA' with the PPRA logo. In the top right corner, there are links for 'Log In' and 'Sign Up'. A navigation menu is located below the header, with links for 'ABOUT US', 'TREATMENT TOOLBOX', 'NETWORK OPTIMIZATION', 'PAVEMENT PRESERVATION', 'RECYCLING', 'EMULSIONS', and 'RESOURCES'. The main content area features the headline 'Find the Best Treatment Solution for Your Road' in large white text, and a sub-headline 'The Right Treatment on the Right Road at the Right Time' in smaller white text below it. A tagline 'Better roads today. Stronger networks tomorrow.' is visible in the top right of the main content area.

RoadResource.org
Provided By: PPRA

Log In Sign Up

Better roads today. Stronger networks tomorrow.

ABOUT US TREATMENT TOOLBOX NETWORK OPTIMIZATION PAVEMENT PRESERVATION RECYCLING EMULSIONS RESOURCES

Find the Best Treatment Solution for Your Road

The Right Treatment on the Right Road at the Right Time

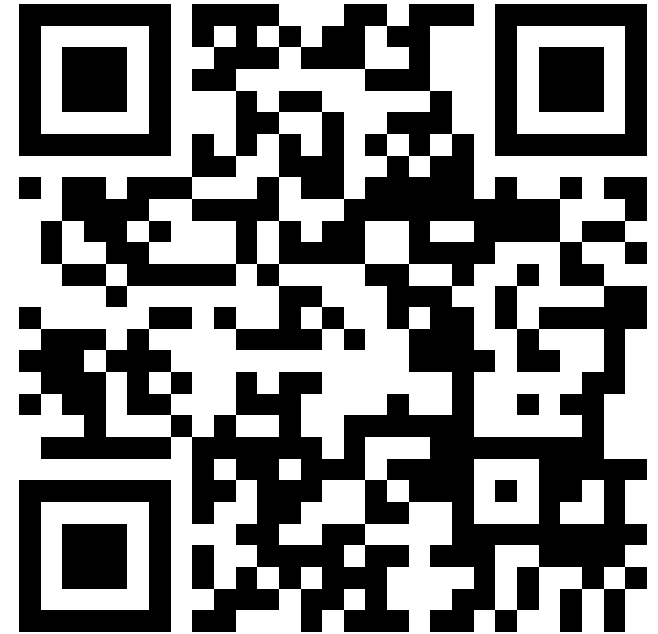

Project Selection and Preparation for Pavement Preservation



Questions to Guide Project Selection

- ▶ Is the intent Preservation or Preservation Maintenance?
- ▶ Do I have any untreated light to moderate cracking?
- ▶ Do I have untreated rutting (+1 / 4 inches)
- ▶ Do I have isolated base repairs?
- ▶ Is a Chip Seal feasible for this location?
 - Traffic, Night Work, High Speed, Political
- ▶ If Preservation Maintenance:
 - What are the Primary and Secondary Distresses?
 - How Quickly is the Deterioration Happening?
 - Is the Pavement Dry and Oxidized or Flushed and Slick?
 - Is there Light (< 1 / 2") or Moderate (> 1 / 2") Rutting?

Preparation for Preservation Projects

▶ Early Stage–

- Crack Treatments
- Structural Leveling
- Full Depth Repairs
- Tree Trimming
- Herbicide Treatment
- Edge Milling
- Micro Milling

▶ Final Stage

- Surface Cleaning
- Structure and Casting Protection
- Pavement Marking Removal
 - Thermoplastic and Buttons
 - Paint is not generally removed unless it is very thick.
 - Pre-Tacking prior to Chip Seal.
- Gutter Protection
- Railroad Crossing Protection

Crack Treatments

- ▶ Crack Treatments Should Always Precede a Surface Treatment
- ▶ All Crack Treatments Should be Completed At Least 30-Days Prior to Surface Treatment.
- ▶ Overband Thickness Should be Less Than 1 / 8”
- ▶ Mastic Applications Should be Flush or Slightly Below the Surface.



Leveling and Full Depth Repairs

- ▶ Surface Repairs Should Be Completed at Least 30–Days Prior to Surface Treatment.
 - Patches less than 30–days old should be fog sealed prior to Chip Seal
- ▶ Patches Should Be Left Flush or Slightly Below the Surface.
- ▶ Ride Quality of Leveling and Patches Must Equal the Desired Ride Quality of the Finished Pavement.

Important Note: Chip Seal and Micro surfacing May Level Slight Depressions in the Pavement. A Bump Will Always Be a Bump!

Edge Milling / Micro Profile Milling

- ▶ Severe Edge Drop Offs on Curb and Gutter Sections should be Edge Milled before Preservation Treatments.
- ▶ Rough, Flushed or Highly Oxidized Surfaces Can be Profile Milled with a Micro Milling Head.

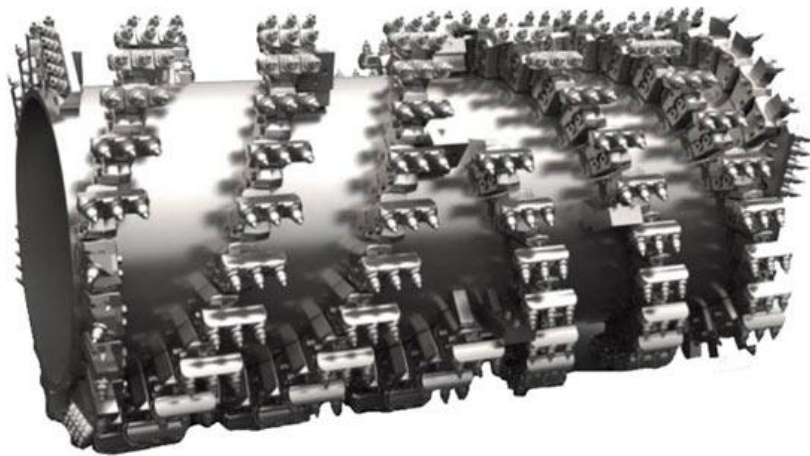

Micro Milled Surface *Fine Milled Surface*

Keystone Mfg.

Why Chip Seal?

- ▶ Chip Seals help preserve the pavement by:
 - Protecting the surface asphalt from oxidation.
 - Oxidation, caused by sun and chemicals make the asphalt cement brittle and more prone to cracking and raveling.
 - Protecting the surface and base from moisture intrusion.
 - Moisture causes:
 - Stripping of base layers
 - Potholes
 - Base Failures
 - Providing a skid resistant, sacrificial wearing surface that protects the underlying surface from traffic wear and damage.

Why Chip Seal?

- ▶ A “chip seal” (also called a “seal coat”) is essentially a single layer of asphalt binder that is covered by embedded aggregate (one stone thick) whose primary purpose is to seal the fine cracks in an underlying pavement’s surface and prevent water intrusion into the base and subgrade.
- ▶ The main advantages of chip seals include:
 - **Improved Skid Resistance:** Chip seals provide good skid resistance,
 - **Cost Effective Treatments:** Chip seals are typically cost effective when properly placed on the right type of pavement,
 - **Good Durability:** By using durable aggregates, chip seals wear well and can have long service lives,
 - **Ease of Construction:** Chip seals are typically constructed rapidly and cause less disruption to the traveling public.

Why Chip Seal?

- ▶ Chip Seal is an effective form of Pavement Preservation.
 - The combination of liquid asphalt and single size chips is an economical tool that provide great value.
- ▶ Chip Seal can also be an effective form of Minor Rehabilitation.



Why Chip Seal?

- ▶ A “chip seal” (also called a “seal coat”) is essentially a single layer of asphalt binder that is covered by embedded aggregate (one stone thick) whose primary purpose is to seal the fine cracks in an underlying pavement’s surface and prevent water intrusion into the base and subgrade.
- ▶ The main advantages of chip seals include:
 - **Improved Skid Resistance:** Chip seals provide good skid resistance,
 - **Cost Effective Treatments:** Chip seals are typically cost effective when properly placed on the right type of pavement,
 - **Good Durability:** By using durable aggregates, chip seals wear well and can have long service lives,
 - **Ease of Construction:** Chip seals are typically constructed rapidly and cause less disruption to the traveling public.

Why Chip Seal

- ▶ Arrests light raveling
 - As asphalt ages, top layer gets brittle
 - Small aggregate begins to wear away
 - Seal coat adds new binder to halt this



Why Chip Seal

- ▶ Provide new wearing course
 - Improves surface friction
 - Lot of data –increase friction numbers to 40+
 - Traffic and weather hit the chip seal first
- ▶ Improve surface appearance



Caution

- A Chip Seal does not add structure to a road
- If you have a bad road before, you'll still have a bad road.





Benh Cat 95022

CRC Computerized Rate Control



SAFETY
KEEP OFF OF MOWER
WHEN ENGINE
IS RUNNING
AVS
DO NOT REAR
SEAT BELT
OR OTHER
RESTRAINTS

Embedment

Average Least Dimension (H)



Embedment (0.7 H)

Inputs that affect Embedment

- ▶ **Materials**
 - Emulsions
 - Aggregates
- ▶ **Equipment**
 - Asphalt Distributor
 - Chip Spreader
 - Rollers
 - Brooms
- ▶ **Application**
- ▶ **Existing Pavement**



CHIP SEAL EMULSION

▶ CRS-2P

- C = Cationic or Positive Charge
- RS = Rapid Set
- 2 = Higher Viscosity
- h = made with a harder base stock – more viscosity
- P = Polymer Modified.

RAP CHIP SEAL EMULSION

- ▶ CMS-2P + REJUVENATOR = PMRE
 - The Rejuvenator does three things:
 - Softens the oxidized asphalt on the existing surface.
 - Softens the oxidized asphalt in the RAP
 - Adds in Maltene Fractions which are the chemical that are lost when asphalt oxidizes.

Why Do We Use Polymer (Latex) in Emulsion?

- ▶ Polymer coats the asphalt particles while they are in suspension. It does not evaporate with the rest of the chemical package.
- ▶ The Polymer:
 - Lowers the temperature at which the asphalt gets brittle.
 - Raises the temperature at which the asphalt softens
 - It can also add strength to the asphalt / aggregate bond

Materials

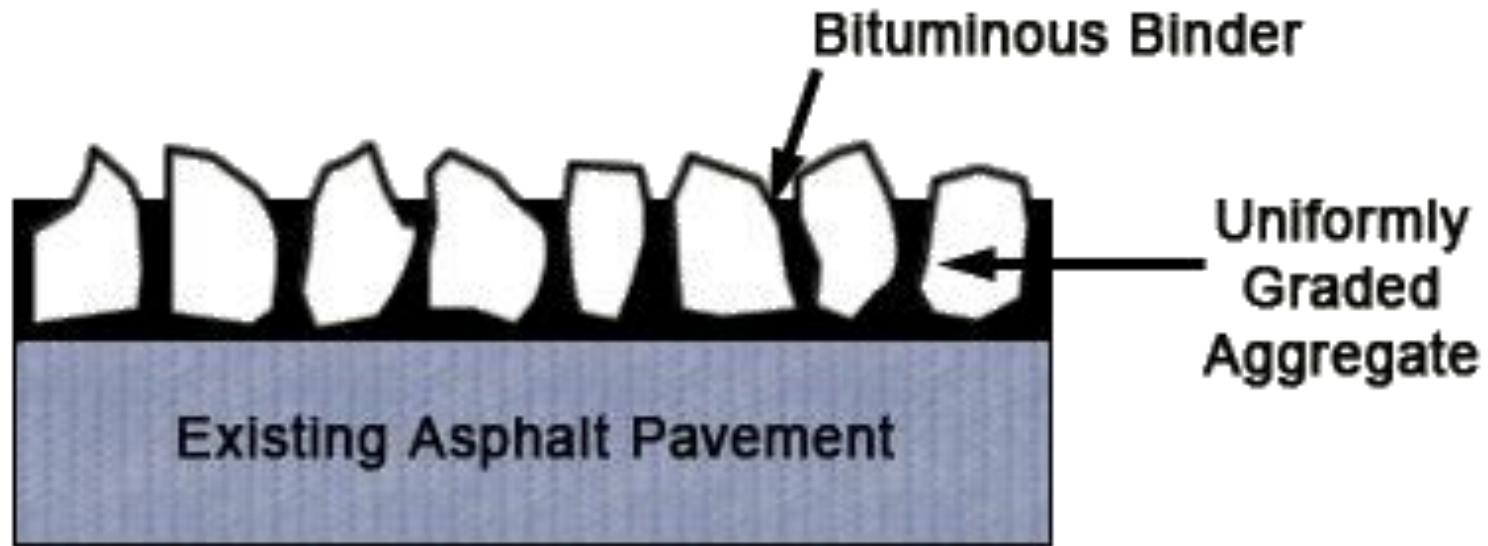

Single Chip Seal

Materials

Dense Graded



Single Size

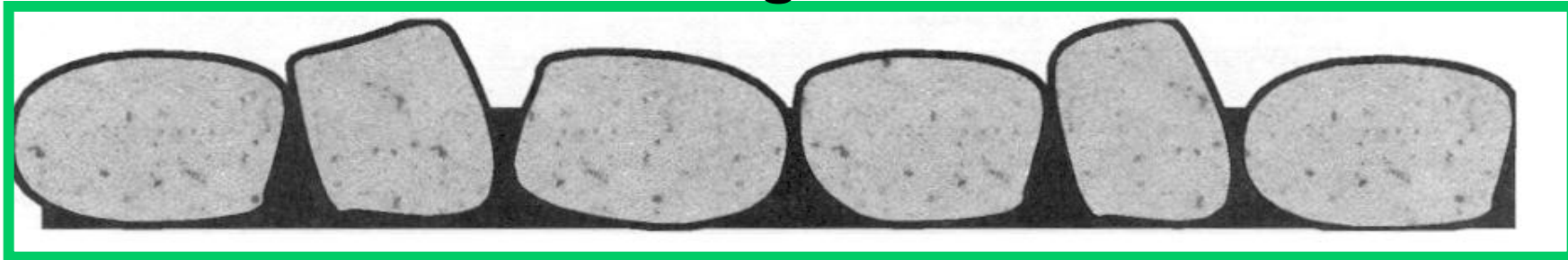

Materials

Best Aggregate Performance when:

- ▶ Single sized
- ▶ Minimum fines
- ▶ Clean
- ▶ Free of clay
- ▶ Cubical
- ▶ Crushed faces
- ▶ Abrasion < 30%
- ▶ Binder compatible
- ▶ Damp for emulsions
- ▶ Dry for hot binders

RAP CHIPS

PREPARATION AND STOCKPILE MANAGEMENT

▶ RAP Piles

- You must know where the RAP came from. Single Source is best.
- Watch for dirt, trash, liquid asphalt and other junk in the pile.

▶ Fractionating (Crushing and Screening)

- Processed RAP should not be stored for long periods of time without rescreening.
- Screening process usually makes 3/8 Chip and Type II slurry aggregate or asphalt screenings.
- May need to double screen or light wash to remove coated fines.

▶ Stockpile Management

- Keep loader off the piles whenever possible.

RAP CHIPS PREPARATION AND STOCKPILE MANAGEMENT



RAP CHIPS

PREPARATION AND STOCKPILE MANAGEMENT



Chip Seal Design

- ▶ “Design” means determining target emulsion and aggregate application rates
- ▶ How do we typically determine how much stone/oil to apply?
 - Spec range
 - Experience

TYPE <i>(see Note 1)</i>	APPLICATION	COVER AGGREGATE SIZE NO. AND COURSE	RATES OF APPLICATION PER SQUARE YARD (SQUARE METER)	
			AGGREGATE lb (kg)	ASPHALT MATERIAL GALLON (LITER) AT 60°F (16°C)
1 or 1P <i>(see Note 2)</i>	Single	23, 24	12-15 (5.4-6.8)	0.12-0.16 (0.45-0.61)
2 or 2P	Single	12	14-17 (6.4-7.7)	0.29-0.33 (1.09-1.25)
3 or 3P	Single	11	16-20 (7.3-9.1)	0.36-0.40 (1.36-1.51)

Chip Seal Design

- ▶ Designs combine:
 - Specific material properties
 - Specific road conditions
 - How much emulsion will the road “drink”?
 - How “dry” is the pavement?



Equipment Condition and Calibration



General Note:

- ✓ No Hydraulic Leaks!

Asphalt Distributor Checklist



Distributor Check List

- ▶ Computerized
 - ▶ Able to Circulate between tank and Bar
 - ▶ Working radar
 - ▶ Working Thermometer for measuring temperatures in the tank.
 - ▶ Heating when required
 - ▶ Gallon Gauge / Calibrated dip stick
 - ▶ Correct tips (nozzles) for application
 - ▶ Strainers are cleaned. No clogs
- 

Why Should You Check Your Distributor's Calibration?

- ▶ To make sure the computer rate matches what's going on The ground
 - ▶ To avoid bleeding or flooding of material
 - ▶ To make sure there is enough material to retain the chip, or assure a good bond for paving surface
 - ▶ To avoid increased cost of material, due to over application
- 

Distributor Checklist

CORRECT

Sprayer Nozzles at Same Angle

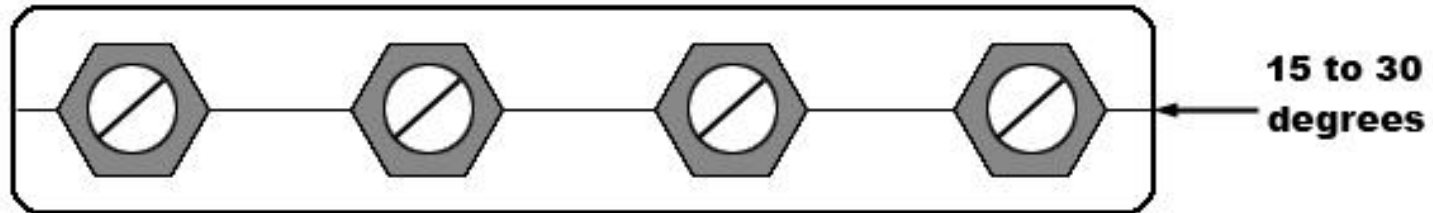

INCORRECT

Sprayer Nozzles at Different Angles

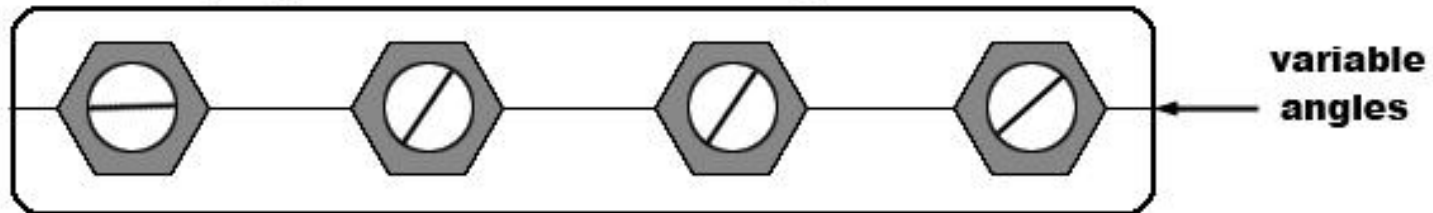

Spray Bar Nozzle Alignment

Distributor Checklist

Same Angle

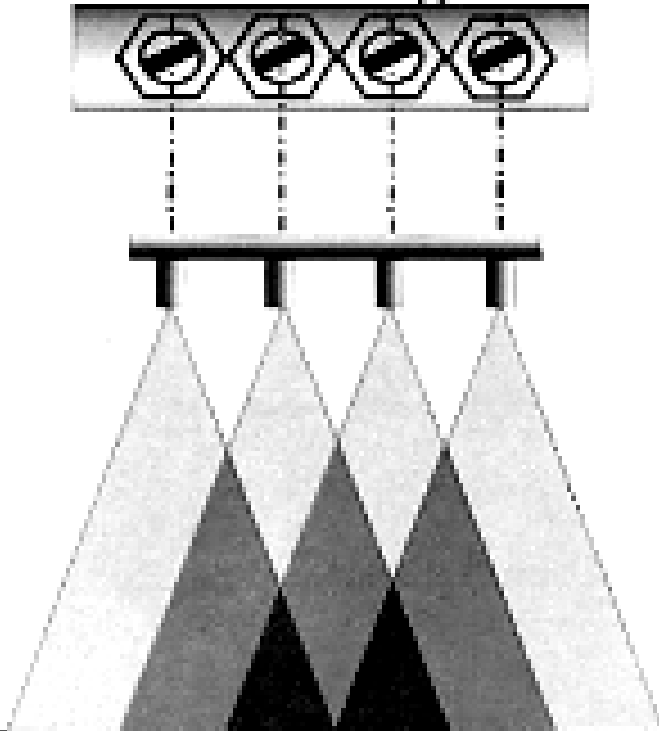

Fans are the same width

Different Angles

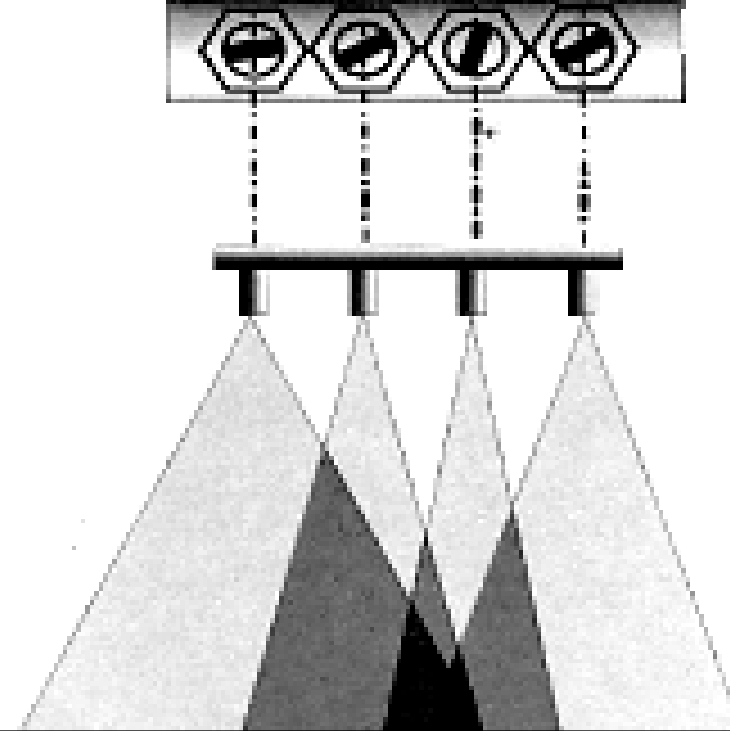

Fans are different widths

Spray Bar Nozzle Alignment

Distributor Checklist

Spray Bar Nozzle Alignment

Nozzle Slot 30° from Spray Bar

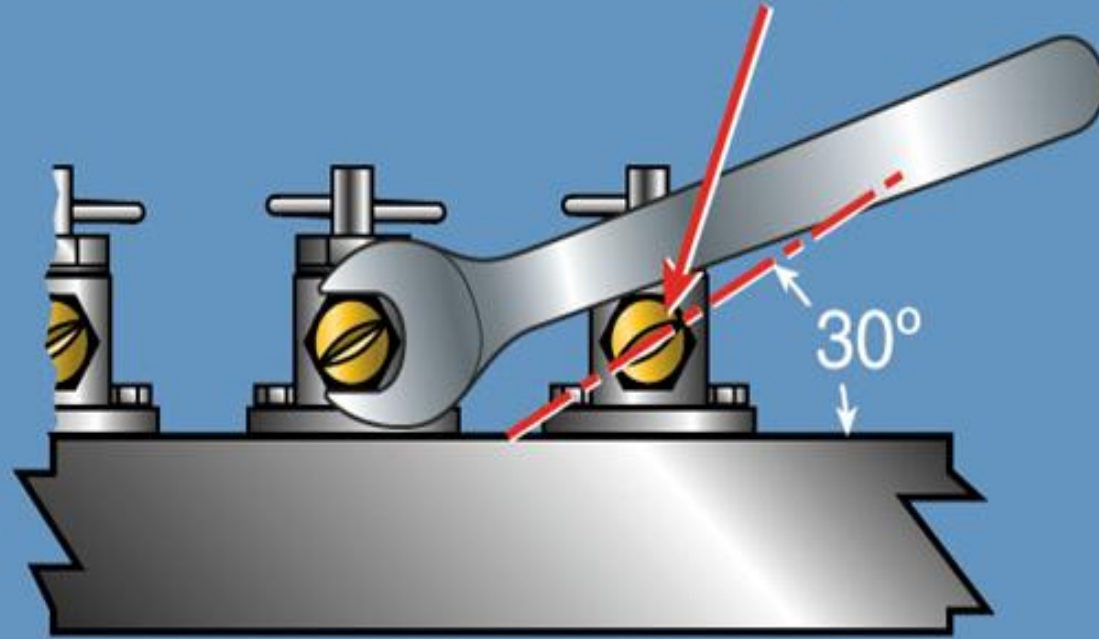

Distributor Checklist

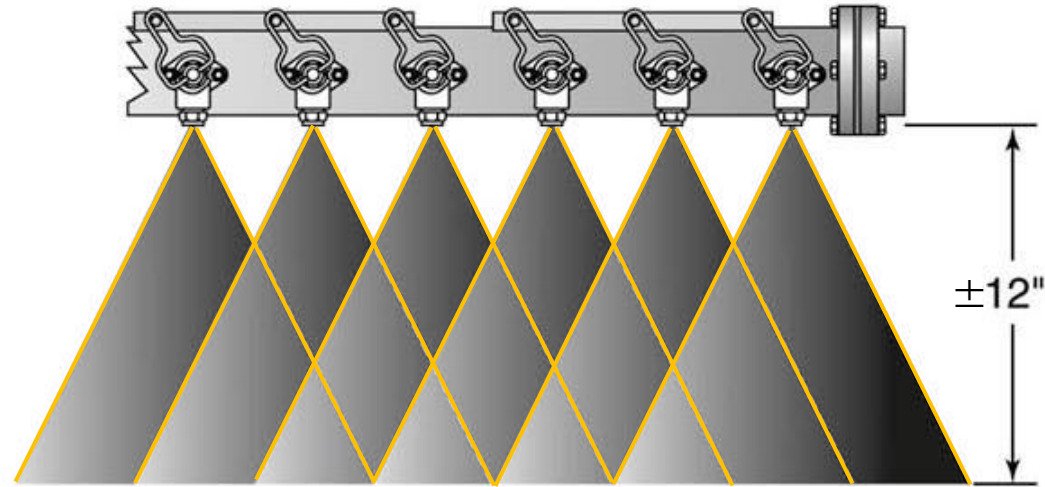

Triple-Lap Coverage

With nozzles on 4" centers, material sprayed from each nozzle overlaps two other sprays.

Calibration

Adjusting Spray Bar Height

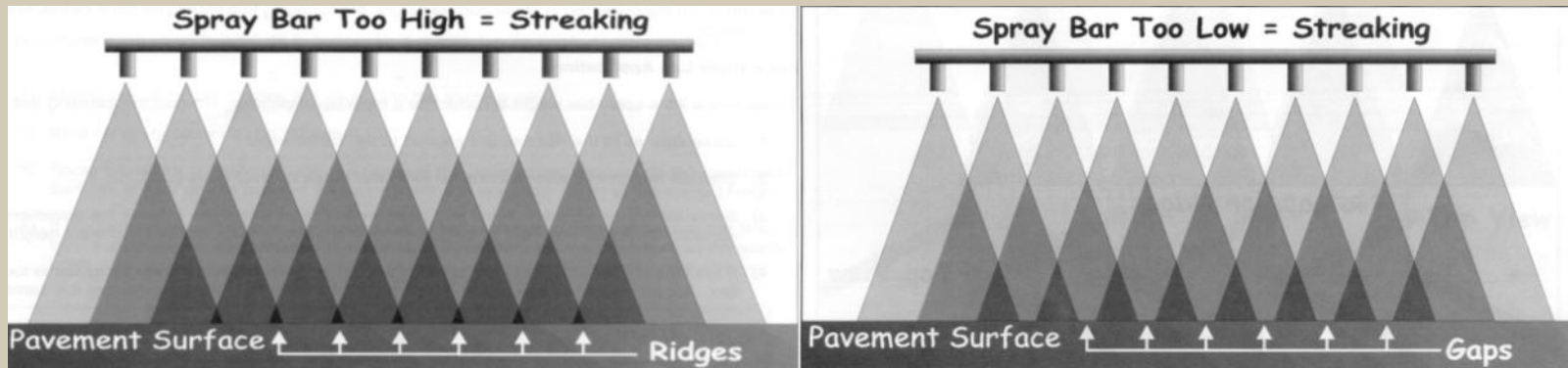

Too High = Ridges

Too Low = Gaps

Stick the Tank

Volume

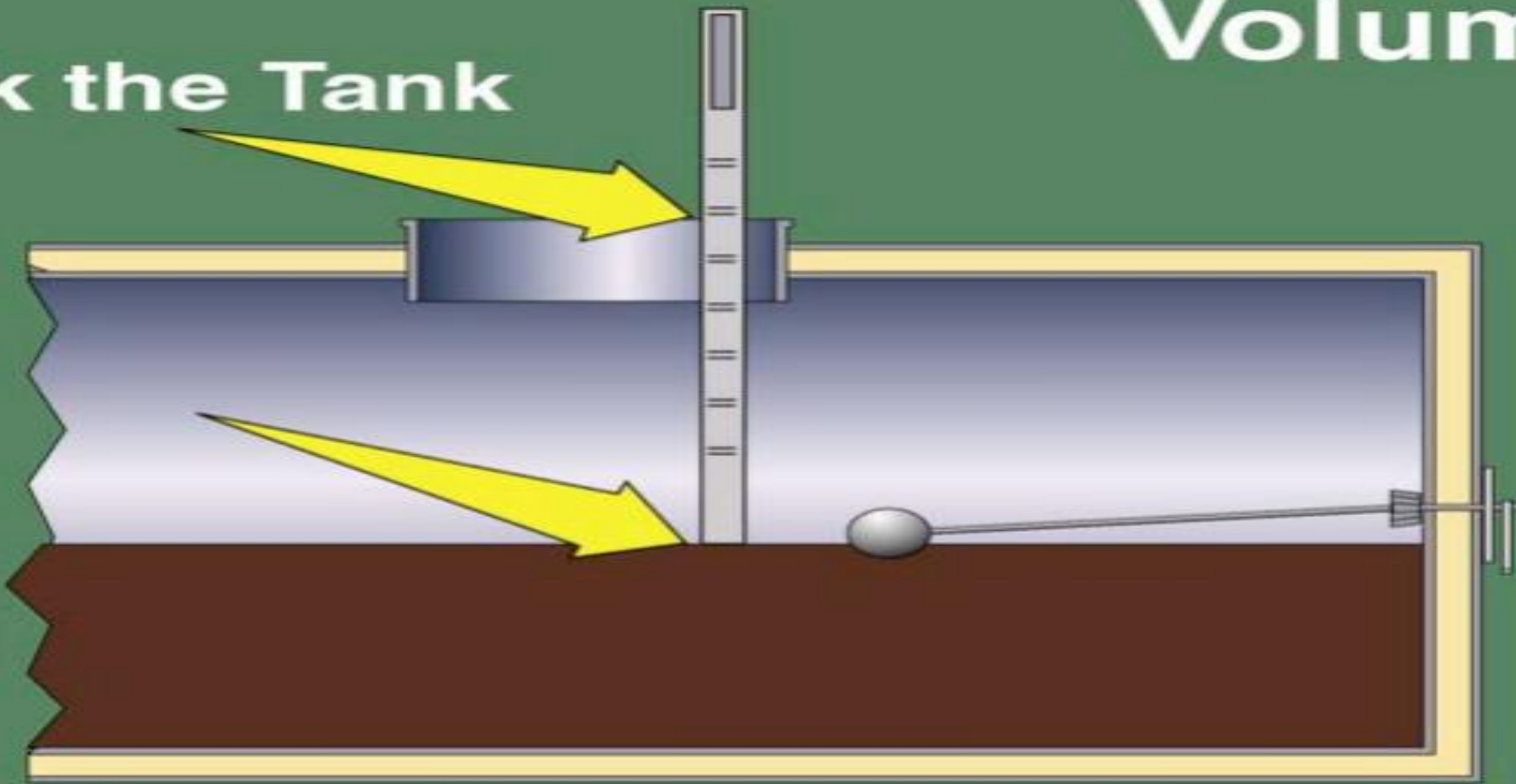

Before checking your volume by sticking the tank, make sure Distributor is level



Weight

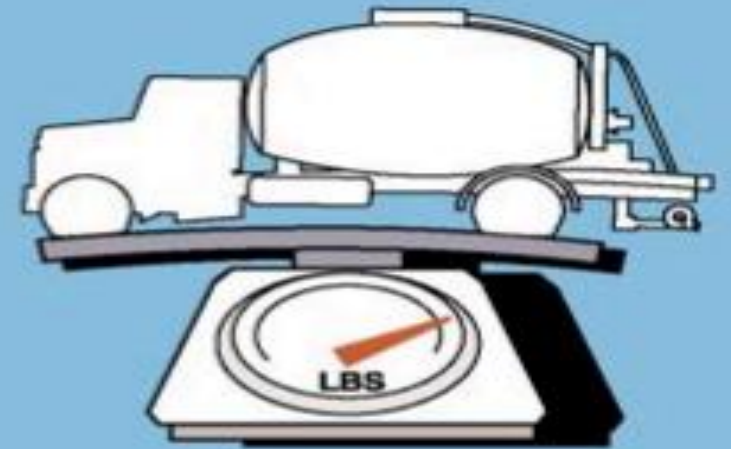

(g/y)

(Feet)

Longitudinal Rate Test

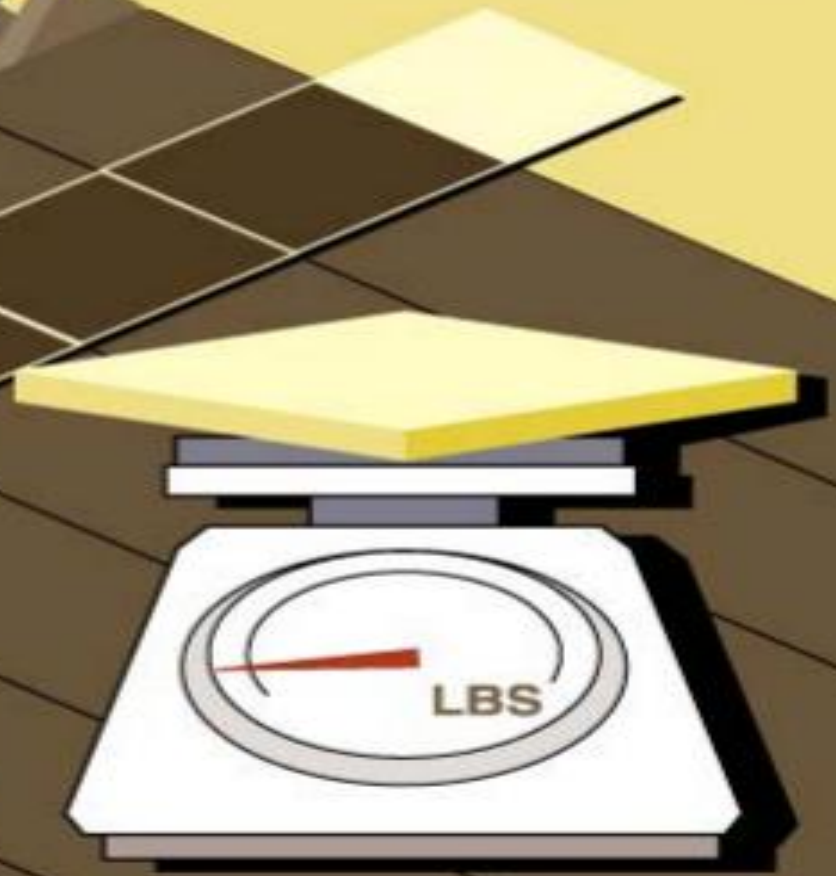

— **Weight**

Distributor Checklist



1
3353788



2
3351008



3
3351009



4
3352368



5
3351015



6
3352204



7
3352205



8
3352210



9
3351014



10
3351010

Ref.	Part No.	Description	Application Per Square Yard	Application (Metric) Liters Per Square Meter	Flow Gallons Per Minute Per Foot
1	3353788	V Slot Tack Nozzle	.05 - .20	.19 - .75	3.0 to 4.5
2	3351008	S36-4 V Slot	.10 - .35	.38 - 1.30	4.0 to 7.5
3	3351009	S36-5 V Slot	.18 - .45		7.0 to 10.0
4	3352368	Multi-Material V Slot	.15 - .40	.57 - 1.50	6.0 to 9.0
5	3351015	3/32" Coin Slot	.15 - .40	.57 - 1.50	6.0 to 9.0
6	3352204	Multi-Material V Slot	.35 - .95	1.30 - 3.60	12.0 to 21.0
7	3352205	Multi-Material V Slot	.20 - .55	.75 - 2.08	7.5 to 12.0
8	3352210	End Nozzle (3352205)	.20 - .55	.75 - 2.08	7.5 to 12.0
9	3351014	3/16" Coin Slot	.35 - .95	1.30 - 3.60	12.0 to 21.0
10	3351010	1/4" Coin Slot	.40 - 1.10	1.50 - 4.16	15.0 to 24.0

#6 Recommended for Chip Seals
Match Nozzles to Application

Shot Rate Adjustments

Pavement Condition	Factor	Adjustment
Flushed asphalt surface	0.70	-0.03 gal/yd ²
Smooth, non-porous surface	0.90	0.00 gal/yd ²
Slightly porous, oxidized surface	0.94	+0.02 gal/yd ²
Slightly pocked, porous surface	0.90	+0.04 gal/yd ²
Badly pocked, porous, oxidized surface	0.90	+0.06 gal/yd ²

Spreader Checklist



Chip Spreader Checklist

- ▶ Uniform aggregate application is a must
 - ▶ Calibrated to ensure consistent discharge across width
 - ▶ Hopper clean and clear of debris and clogs.
 - ▶ Spread Hopper Gates are set correctly.
 - ▶ Well Maintained, no hydraulic leaks.
 - ▶ Correct Tire Pressure
 - Unit will bounce if pressure is too high.
- 





Haul Trucks Checklist

- ▶ Compatibility
- ▶ Dirty Tires cause “pick ups”
- ▶ No sharp turns
- ▶ Enough trucks to do the job
- ▶ No Leaks
- ▶ Stagger wheel paths
- ▶ Chip Bar and Tailgate latch required.
- ▶ Watch the Air Tank Bleed Valve. Can damage seal if directed straight down.



Check each truck for hitch acceptance!



Stockpile and Loader Checklist

- ▶ Loader must be leak free
- ▶ Stockpile must be clean and stable to avoid contamination of aggregate.
- ▶ Stockpiles free draining avoid water entrapment
- ▶ Minimal handling will help reduce degradation.



Roller Checklist

- ▶ Nine Wheel Pneumatic Rollers
- ▶ Minimum two rollers, three is best
- ▶ Orients aggregate on flattest side.
- ▶ Embeds aggregate in binder
- ▶ Achieves mechanical lock of aggregate particles
- ▶ 8 ton minimum
- ▶ Tire Pressure
 - 85 psi
 - No variance of more than 5 psi between all tires



Broom Checklist

- ▶ Self propelled
- ▶ Four Wheels
- ▶ Watch Speed – Do No Harm
- ▶ Plastic Bristles (Not Wire)
- ▶ Cleans existing road surface and joints
- ▶ Used to remove excess aggregate when binder is fully cured.
- ▶ Water may be used for dust.
- ▶ Rotary / Vacuum / Pick up



Application Strategies



Road Preparation Checklist

- ▶ Weed Removal Complete
- ▶ Fog Longitudinal Paint Lines
- ▶ Thermo-Plastic striping removed
- ▶ Pre-Sweep Complete
- ▶ Utilities Protected
- ▶ Temporary Markings in Place



Traffic Considerations

- ▶ Ideally, keep traffic off until emulsion cures sufficiently to hold the aggregate.



Traffic Considerations

- ▶ Control traffic by:
 - Use of pilot vehicles
 - Pilot vehicle is the lead through the workzone.
 - Maintains low (15 mph) speed.
 - Close road
 - Advance notice signage, alternate route
 - Multilane roads – keep lane closed



Equipment Placement

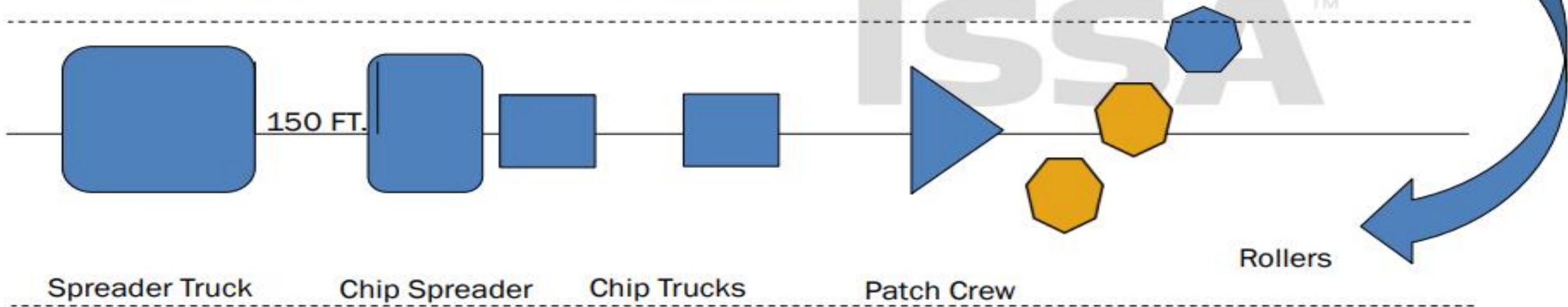

Emulsion/Agg Spreading

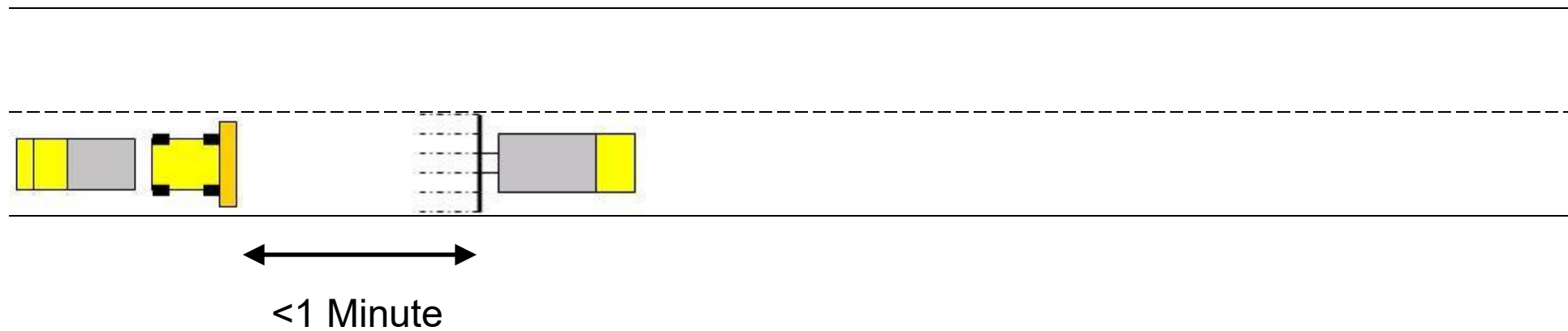

This way...

Distributor and Agg Spreader Virtually Joined Together

Emulsion/Agg Spreading

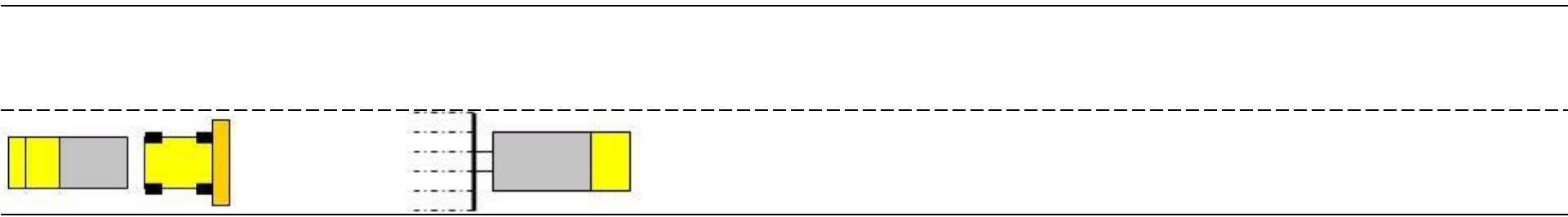

NOT this way...

Causes too many joints, and may cause uneven chip retention

Application Checklist

- ▶ Air and Ambient Temperature above 55F*. Above 40F overnight
- ▶ Dry pavement, no rain forecast for 24 hours.
- ▶ Emulsion heated to manufacturers requirements (145 – 185F)
- ▶ Aggregate damp but not wet
- ▶ Tar Paper set at beginning and end of emulsion shot.
- ▶ Chip Spreader width set to leave a narrow strip of uncoated emulsion.



Application Checklist

- ▶ Chip Spreader stays within 150 ft. of Asphalt Distributor.
- ▶ Adjust speed so that Chip Spreader doesn't bounce.
- ▶ Stop after first 1,000 ft. Check for:
 - Emulsion Application Rate
 - Too Little Emulsion is much worse than Too Much!
 - Aggregate Application Rate
 - Salt and Pepper
 - Embedment
 - Quality of Mat
 - No streaks, ridges, pickups



Aggregate Application

- ▶ Don't over apply
 - Ideally, 1 stone thick
 - Too much is as bad as not enough
 - “Salt and Pepper” appearance

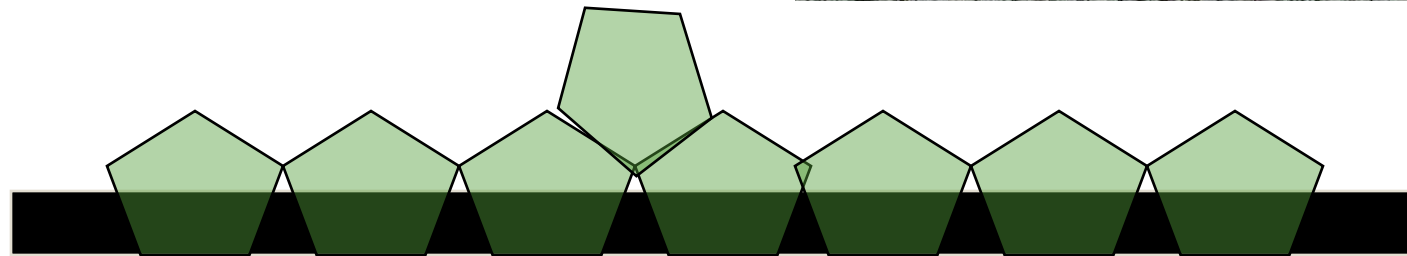

Application Checklist

- ▶ Enough rollers available to make three passes while keeping up with the Chip Spreader without exceeding 3 – mph.
- ▶ Watch for rooster tails of dislodged aggregate for fast rolling.
- ▶ Rollers limit turning and stopping on fresh seal.
- ▶ Keep tires clear of emulsion.



Construction

- ▶ Rollers
 - At least 3 passes (“Applications”)
 - 2 Roller Pattern
 - 3 Roller Pattern

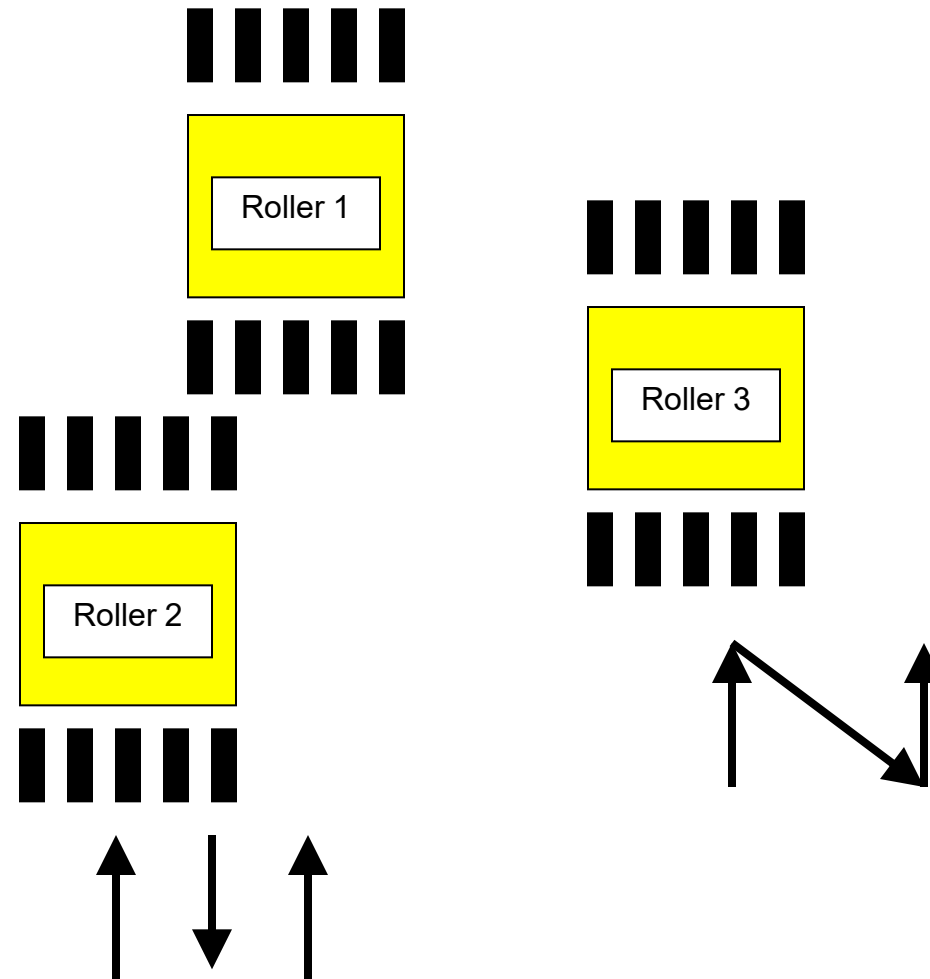

2 Roller Preferred Pattern

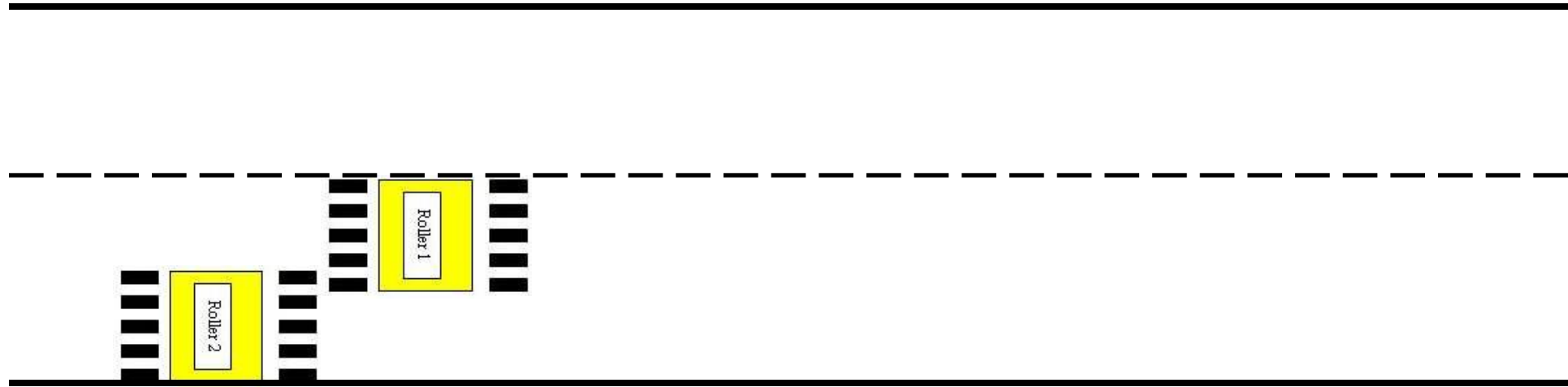

Both rollers stay in line

3 Roller Preferred Pattern

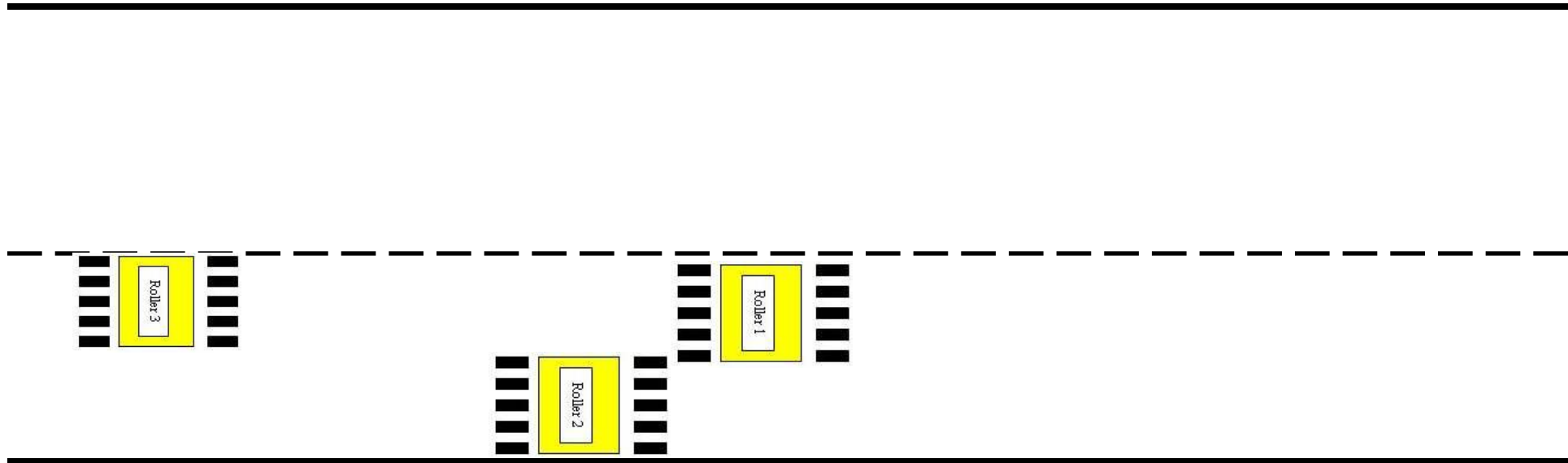

Rollers 1 and 2 stay in line (same as 2 roller pattern),

Roller 3 zigzags

Application Checklist

- ▶ Brooming should start when emulsion is cured; usually between one and two hours after rolling.
- ▶ Light brooming only. Heavy brooming removes excess chips. Excess chips remove other chips. Embedment is lost.
- ▶ Broom centerline joint if necessary.
- ▶ Open to controlled rolling traffic as soon as safely possible



Final Thoughts

- ▶ Remember, Embedment of the stone is key!
- ▶ Everything you do should be aimed at achieving proper embedment and minimum stone loss.

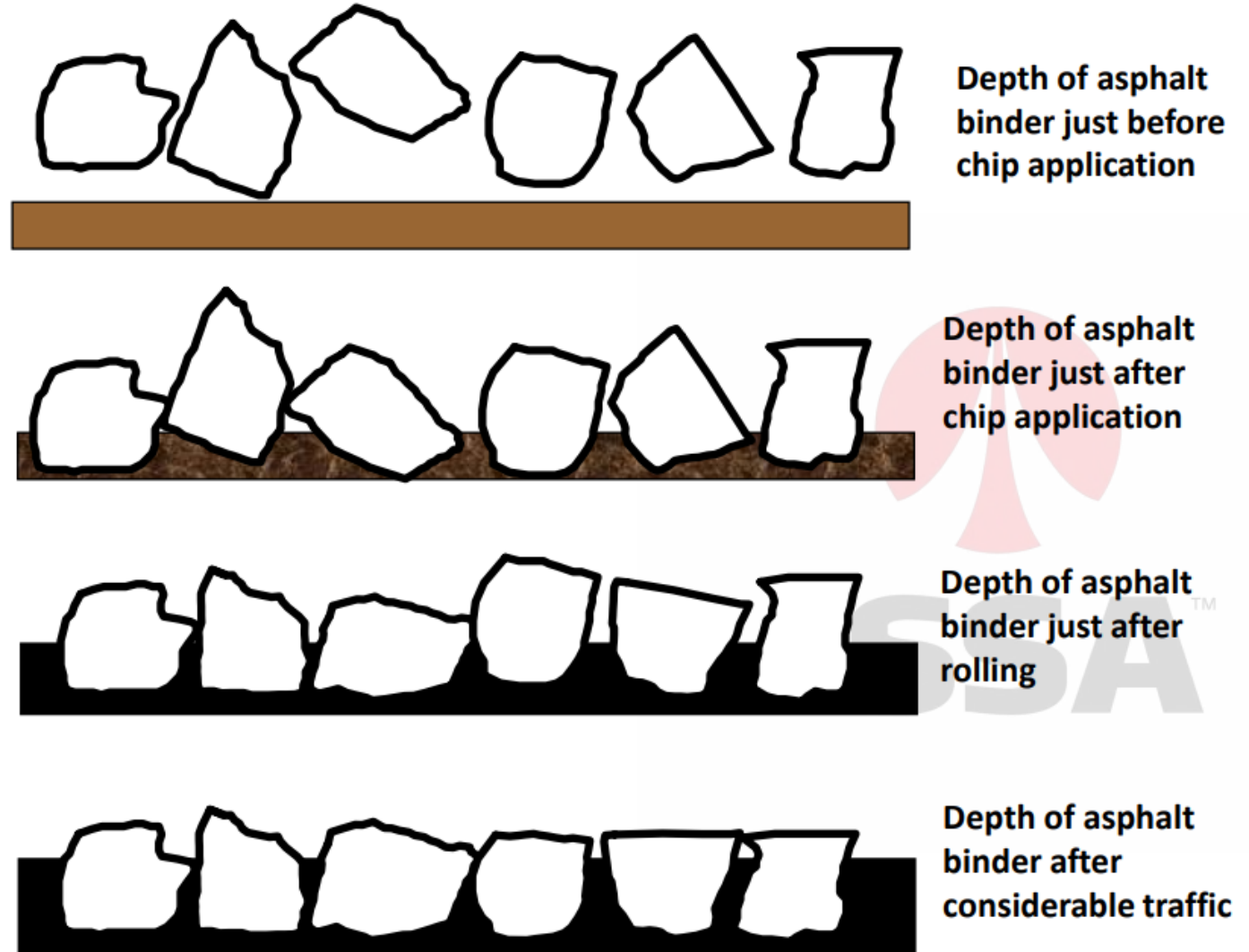

Aggregate Application



Fog Seal



Why Fog Seal?

▶ Dense Graded HMA

- Protects asphalt from oxidation and moisture intrusion
- Reduces raveling on dry mixes
- Fills fine cracks

▶ Chip Seals

- Protects asphalt from oxidation and moisture intrusion.
- Locks In Chips
- Reduces Snowplow damage
- Dark surface helps with snow and ice melt.
- Dark surface highlights traffic markings

Fog Seal Materials

▶ Emulsion

◦ CSS-1h

- Pre-Diluted to 27 to 35% residual by manufacturer
- Do not field dilute
- Heat CSS-1h to 150 F prior to application
- Never heat CSS-1h over 185 F

▶ Blotter Aggregate

◦ Fine Aggregate

- Used as needed (pedestrian traffic, over applied emulsion)

Application Rate

- ▶ Emulsion Application Rate typically ranges from 0.10 gal/sy to 0.15 gal/sy.
- ▶ Start test strip application at .12 gal/sy to make sure surface isn't flooded.
- ▶ Adjust as needed to completely coat surface without puddling.



Distributor Best Practices

- ▶ Set spray bar at 12" Height to ensure triple overlap
- ▶ Check Nozzle Alignment
 - Outside nozzles may be turned for straight edgeline.
- ▶ Ensure correct distributor nozzles
 - Etnyre Part # 3353788
 - Different than Chip Seal Nozzles

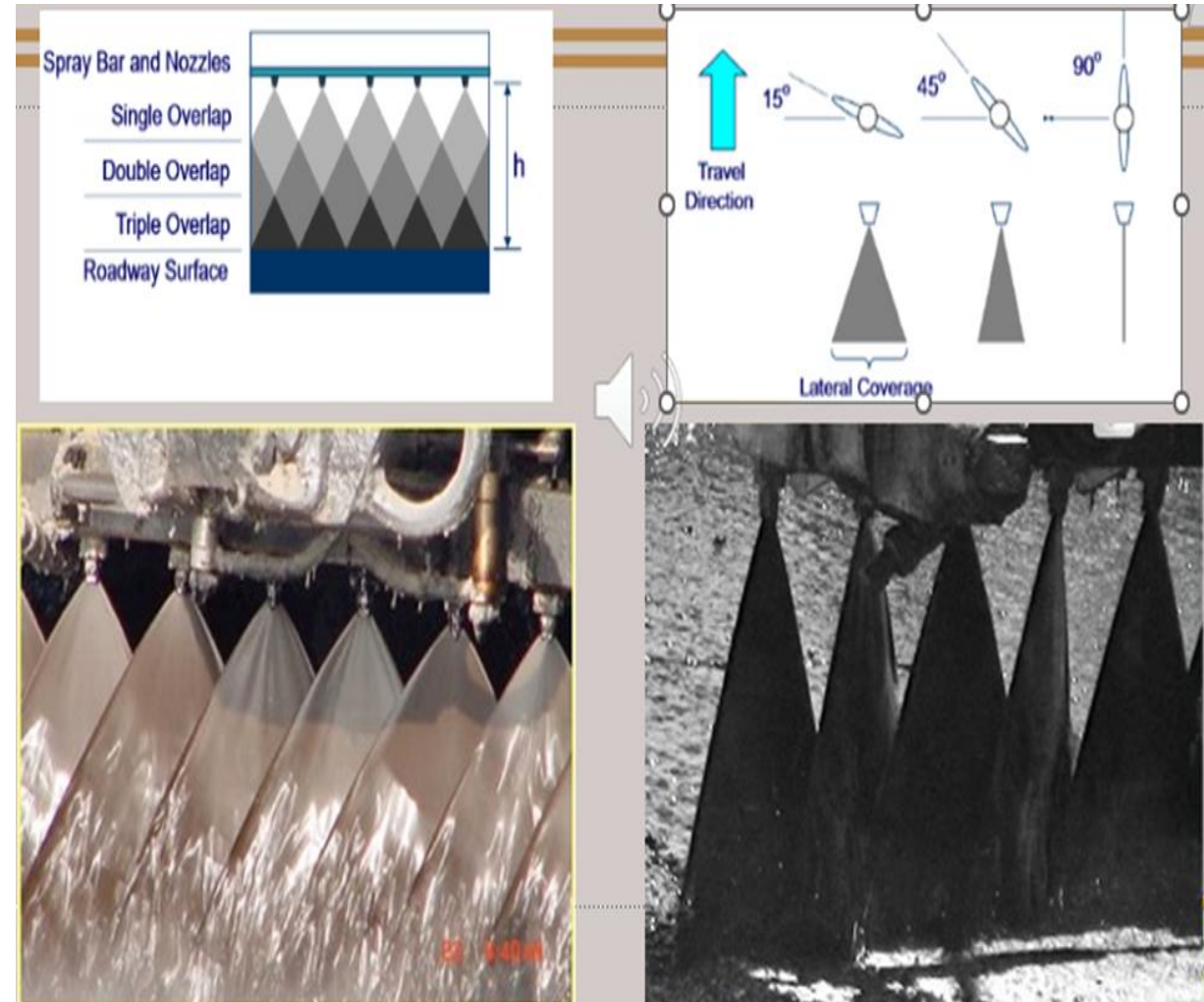

Application Best Practices

- ▶ Sweep roadway immediately ahead of Fog Seal Operation.
- ▶ Cover all Manholes, Valley Gutters, etc.
- ▶ Start with a 500 ft. Test Strip to check application rate, nozzles, spray bar height.



Opening To Traffic

- ▶ Allow the asphalt emulsion to cure before permitting traffic.
- ▶ Minimum cure time is 30 minutes but may extend due to environmental conditions, application rate and emulsion residue content.



Troubleshooting

- ▶ Excessive Splattering
 - Bar height is incorrect
 - Spray pressure is too high
- ▶ Streaking
 - Cold emulsion
 - Nozzle angles are incorrect
 - Bar height is incorrect
 - Plugged nozzles
 - Pump pressure too low
 - Clogged Screens
- ▶ Bleeding or Flushing
 - Application rate too high



SPECIFICATION REVIEW



SECTION 403 – CHIP SEAL COAT WARRANTY

403.01 Description.

Construct a chip seal at least 1 layer of asphalt followed by 1 layer of aggregate. Warrant the quality of work and materials against contractor-obligated defects (COD) for the warranty period as specified in this section. Noncontractor-obligated defects (NCOD) will not count against the warranted work. Applying a fog seal over the chip sealed area is at the discretion of the Contractor unless otherwise specified. A chip seal area determined to be a catastrophic failure will be repaired and the warranty will be extended for an additional year.

The chip seal work will be evaluated using the current version of the Department's Chip Seal Coat Warranty Guide.

403.02 Materials.

Provide materials in accordance with the following:

1. Asphaltic binder. Meet the requirements of 702.03. Type, grade, and other binder characteristics (e.g., viscosity, chemical composition) of the binder is the Contractor's option.
2. Use the specified class of aggregate, meet quality requirements in 703.01, and gradation in 703.06-1.

Submit the following quality control tests:

Table 403.02-2 – Contractor-Provided Tests

Test	Test Method	Frequency	Point of Sampling	Specifications
Gradation	AASHTO T 27	1 test minimum per 400 tons	From crusher	Cover Coat Aggregate See Table 703.06-1
Fracture Count	AASHTO T 335	1 test minimum per 400 tons	From crusher	70% with at least one fractured face
Cleanness Value	Idaho IT 72	1 test minimum per 400 tons	At point of loading the roadway	—

3. Submit documentation of the materials (e.g., type and grade of binder) used, control tests charts, and other pertinent data.

403.03 Construction Requirements.

The Contractor is responsible for determining the best method and means to construct the chip seal. Public and private property damage claim(s) will be forwarded to the Contractor for consideration.

A. Existing Roadway Conditions.

Before chip sealing, the existing roadway conditions that may result in NCODs will be identified and documented in writing by the Contractor and submitted for approval. Pictures of potential NCOD areas are suggested. If approved, these preexisting conditions will be excluded and not considered CODs. If there is a disagreement between the Engineer and the Contractor on what is expected to be a NCOD, the Contractor will put in writing the disagreement including their reasoning and any supporting documentation (e.g., pictures).

B. Preparation for and Application of Chip Seal.

1. Cover and protect existing manholes, valve casings, road weather information systems (RWIS) sensors, weigh-in-motion site sensors, expansion joints, drains, street monuments, and other items as directed before chip sealing. Retain and protect cattle guards and weigh-in-motion concrete pads. If protection of these items is not possible, inform the Engineer before chip sealing and request direction. Remove protection after chip seal is complete.
2. Clean the pavement surface before chip sealing.
3. Do not chip seal bridge decks or approach slabs. After chip seal completion, remove and dispose of asphalt, aggregate, and other material that may have spilled into deck drains and expansion joints.
4. For beginning and ending joints, mask the roadway with effective material (e.g., building paper) to create a fine and definite transverse line.
5. Meet-lines must be within 1 foot of lane lines or within 1 foot of center of lanes. Meet-lines are not allowed within a wheel path. Ensure transverse and longitudinal joints are smooth and match the adjacent surfaces.
6. Do not apply chips during the 48-hour period immediately preceding a holiday or a holiday weekend. Brooming and pilot car operations are allowed within this 48-hour period.
7. When not spreading, park the distributor to ensure the spray bar or mechanism will not drip on the surface.

C. Brooming.

1. Broom loose chips from the roadway and other areas listed in 403.03.C.2 at the end of each day's operations. The Department requires the Contractor to broom at least 2 complete coverages, with the second brooming approximately 24 hours after the first brooming. Additional brooming may be necessary to receive limited chip seal acceptance of the work.
2. Use a mechanical rotary type broom. Use a mechanical pickup or vacuum broom for the following conditions:
 - a. In curb/gutter and on sidewalk sections.
 - b. In all guardrail areas.
 - c. On bridge decks.
 - d. Within 100 feet of bridges that span water channels (wet or dry).
 - e. Within 100 feet of adjacent wetlands and surface waters that reside within the right of way.
 - f. Maintained shoulder-foreslope areas where the adjacent property owner cares for and maintains turf or landscaping.
3. Provide dust control using water or other approved means during brooming.
4. Pick up and properly dispose of excess materials.
5. After the second brooming meets the Department's satisfaction, the Department will accept the brooming in writing before opening the road to full speed traffic, unless otherwise directed.

D. Limited Acceptance, Warranty Period, and Warranty.

After brooming has been accepted, CODs in the work will be documented. The CODs that do not exceed the COD threshold may be left to monitor or be repaired. The CODs in excess of the COD threshold will be repaired before limited chip seal coat warranty acceptance is granted. The Department will acknowledge in writing limited chip seal coat warranty acceptance along with any noted CODs or NCODs. In the event of a disagreement between the Department and the Contractor on what is expected to be a NCOD, the Contractor will put in writing the disagreement including their reasoning and any supporting documentation (e.g., measurements, pictures).

The warranty period begins upon receipt of the written limited chip seal coat warranty acceptance and continues until April 1 of the following year. If CODs are documented before warranty repair work and the CODs continue to spread or magnify after April 1, all CODs must be repaired.

It is the Department's and the Contractor's responsibility to monitor, document, and communicate the emergence of NCODs or CODs throughout the warranty period. The Department and the Contractor will evaluate and photo document the roadway before snow plow season. If NCODs or CODs are discovered during the warranty period, the Engineer and the Contractor will notify the other party in writing of their discoveries.

The Department will use its resources to handle insignificant warranty repair work (e.g., applying blotter after the limited chip seal coat warranty acceptance) at the request of the Contractor and the availability of the Department's resources. Costs incurred by the Department for roadway maintenance of the chip seal directly associated to any CODs will be deducted from subsequent progress estimates.

During the warranty period, if the Department or the Contractor determine chip loss is beyond reasonable and resulting in windshield damage or other safety concerns to traveling motorists, the Contractor will re-broom as needed, coordinate with the Department to re-broom, or submit a repair solution for approval that resolves the safety concerns as soon as practical.

E. COD Threshold Determination.

The Contractor warrants that the chip seal (travel lanes, shoulders, turning lanes, and other areas as specified) will have a total COD area within the allowable limits for the warranty period.

In April following the Engineer's limited chip seal coat warranty acceptance or sooner if conditions warrant, the Contractor will arrange a meeting with the Engineer, if necessary, to conduct an onsite evaluation to review and document NCODs and CODs. The Engineer will provide in writing the final decisions on what repairs are required in accordance with the Department's current version of the Chip Seal Coat Warranty Guide and 105.03.

Warranty repair work will be required if the total COD area exceeds the specified threshold of 1.5 percent or more than 1 of the following guidelines is met:

1. If separate COD areas total approximately 50 square yards in a 0.1 mile section and there are other CODs under consideration.
2. If an individual COD area is greater than 100 square yards in total area and there are other CODs under consideration.
3. If there are regularly occurring individual CODs and there are other CODs under consideration.
4. If a COD is linear in nature, regardless of width (approximately 300 feet or more) and there are other CODs under consideration.

If the Department determines the required repair work will not benefit the traveling public, and if agreed by both parties, financial reparation will be considered instead of repair work at a cost of 2 times the bid amount price per square yard.

F. Warranty Repair.

If it is determined that the CODs threshold is exceeded, submit a repair plan and repair schedule for approval before starting repairs. Complete repairs by August 31. If repairs cannot be made by August 31 due to events outside the control of both parties as specified in 107.11, both parties will agree to an acceptable repair by date.

Perform warranty repair work as approved in the Contractor's repair plan at no additional cost to the Department. The repair may be localized or be full reconstruction depending on the CODs identified. Use the same source for any localized warranty repair work as the original source. If this is not possible, the Engineer will consider other sources that have similarly colored aggregate. Warranty work includes replacing all pavement markings and any other permanent features that are damaged or obliterated due to the chip seal failure or repair process at no additional cost to the Department.

The Engineer will terminate the chip seal coat warranty when the chip seal is accepted or the required warranty repair work has been completed. The chip seal coat warranty does not apply to the warranty repair work.

G. Pavement Markings.

Pavement markings will be applied in accordance with Department standards and the MUTCD.

H. Catastrophic Failure and Repair.

A catastrophic chip seal failure is defined as a total COD area that equal or exceeds the specified threshold of 40 percent. If a limited acceptance chip seal coat warranty was already issued before the catastrophic failure occurred, the limited acceptance will be immediately revoked. Upon completion of the repairs, a new limited chip seal coat warranty acceptance will be made and only the catastrophic areas repaired will have an extended warranty period.

The repair plan of a catastrophic chip seal coat failure will be approved by the Engineer and may include removing the remaining chips before re-chip sealing the roadway (e.g., if there is little confidence the remaining chips will stay imbedded in the roadway) and applying a fog coat. As needed, brooming will be required until the repair is completed.

If the Department determines the required repair work will not benefit the traveling public, and if agreed by both parties, financial reparation will be considered instead of repair work and the extended warranty at a cost of 2 times the bid amount price per square yard.

403.04 Method of Measurement.

The Engineer will use plan quantity of acceptably completed work by the square yard.

403.05 Basis of Payment.

The Department will pay for accepted quantity at contract unit prices as follows:

Pay Item	Pay Unit
Chip Seal Coat Warranty	SY



- A Application of Aggregate
Maintain the Aggregate application rate within 1 pound per square yard of the mix design.
- Blend Aggregate at the stockpiles to provide uniformly damp material.
- Place Aggregate within 1 minute after applying the bituminous Material.
- Do not use previously applied Aggregates.
- B Rolling Operations
Complete the initial rolling immediately after applying the Aggregate at a speed no greater than 5 mph to prevent turning over Aggregate. Make at least 3 complete passes over the entire width of the treatment area.
- C Sweeping
Remove surplus Aggregate on the same day as the scrub seal construction. Resweep areas the day after the initial sweeping.
- Provide at least one street sweeper (with pickup broom) on roadways with curb and gutter to remove loose aggregate. Dispose of the swept material in accordance with MnDOT 2104.3D.3.
- D Protection of the Surface
Do not allow traffic on the scrub sealed Road surface until after the initial sweeping is completed.
- E Protection of Motor Vehicles
The Contractor is responsible for damages claims; insurance in accordance with MnDOT 1714.

The warranty repair work, including the necessary traffic control and striping, will be at no additional cost to the Department.

Work associated with chip sealing is incidental, including:

1. Cleaning the pavement surface.
2. Protecting existing manholes, valve casings, street monuments, and RWIS sensors. Remove and dispose materials used for protection after chip sealing is completed.
3. Restoring items that were not properly protected
4. Providing and applying materials, including asphalt, cover coat aggregates, and blotter, if necessary.
5. Water applications.
6. Brooming.
7. Maintaining the roadway surface until receipt of written limited acceptance.
8. Removing and disposing excess material.
9. All other work necessary to chip sealing.

The Contractor is eligible to receive 100 percent of payment for work completed after limited acceptance has been issued. The Contractor's performance bond will be used as the chip seal warranty bond. The entire value of the performance bond must remain in effect for the duration of the chip seal coat warranty. The Department will release the performance bond as specified in 103.04 after the Engineer terminates the chip seal coat warranty.

SECTION 404 – SURFACE TREATMENT

404.01 Description.

Construct a single or multiple course surface treatment that may consist of the application of 1 or more chip seal coats or may consist of a prime coat followed by 1 or more chip seal coats as follows:

1. Type A: Apply a chip seal coat.
2. Type B: Apply a prime coat followed by the application of a chip seal coat.
3. Type C: Apply 2 chip seal coats.
4. Type D: Apply a prime coat followed by the application of 2 chip seal coats.

A fog coat may be constructed on any of the types of surface treatments, as specified.

404.02 Materials.

Provide materials as specified in:

Asphalt	702.01
Emulsified Asphalt	702.03
Anti-Stripping Additive	702.04
Aggregate for Cover Coat Material	703.06
Aggregate for Blotter and Aggregate for Choke Sand	703.07

Provide asphalt of the type and grade specified. Provide asphalt and anti-stripping additive, if required, as specified in 702. The Engineer will accept the asphalt at the point of delivery.

The emulsified asphalt is subject to viscosity and sieve testing by the Department, in the field or at a location other than the project site. Schedule the delivery time to allow testing before usage. Expect delays up to 1 hour for this testing.

Provide cover coat material, blotter, and choke sand as specified in 703. The Engineer will accept the cover coat material, blotter, and choke sand at the point of loading for delivery to the roadway.

Submit a chip seal coat design for each stockpile using the McLeod method at least 2 weeks before construction. Field-verify the chip seal coat design for spread rate of asphalt and aggregate.

404.03 Construction Requirements.

A. Chip Seal Coat.

Do not apply asphalt if the roadway surface or weather conditions can prevent satisfactory construction.

Do not start chip sealing unless the pavement surface temperatures are 80°F and rising, and do not chip seal when pavement surface temperature exceeds 140°F, unless authorized in writing. If bleeding becomes apparent on the completed chip seal, start immediate maintenance and traffic control, and do not continue chip sealing until corrective action has been started.

Do not apply chip seals when the wind velocity exceeds 15 mph without written approval.

Do not apply chip seals before June 15 or after September 1.

The following equipment or its equivalent is required by the Department:

1. Asphalt application equipment for applying asphalt. An asphalt distributor and equipment for heating the asphalt. Ensure the distributor is designed, equipped, maintained, and operated so asphalt can be applied uniformly on variable widths of surface at readily determined and controlled rates with uniform pressure. Provide distributor equipment that includes a tachometer, pressure gauges, accurate volume measuring devices or a calibrated tank, and a thermometer for measuring temperatures of tank contents. Equip distributors with a power unit for the pump and full-circulation, vertically adjustable spray bars.
2. Brooms. Use a mechanical rotary type broom. Use a mechanical pickup or vacuum broom for the following conditions:
 - a. In curb/gutter and on sidewalk sections.
 - b. In all guardrail areas.
 - c. On bridge decks.
 - d. Within 100 feet of bridges that span water channels (wet or dry).
 - e. Within 100 feet of adjacent wetlands and surface waters that reside within the right of way.
 - f. Maintained shoulder-foreslope areas where the adjacent property owner cares for and maintains turf or landscaping.
3. Pneumatic-tire Rollers. Do not operate the rollers at a speed in excess of 8 mph. Include enough pneumatic-tired rollers to cover a full spread width with 1 pass. Use compaction equipment and/or rolling methods to produce the required compaction without damaging the work.
4. Self-propelled aggregate spreader supported by at least 4 wheels equipped with pneumatic tires on 2 axles, of Engineer approved design. Equip the aggregate spreader with positive controls so that the required amount of material will be deposited uniformly over the full width required.

Seal approaches before sealing the adjacent roadway.

Do not chip seal bridge decks and approach slabs. Protect drains and bridge expansion joints from the chip seal application, then remove and properly dispose of material used for this protection after completion of the chip seal. After chip seal completion, remove asphalt and aggregate that may have spilled into drains and deck expansion joints.

Do not spread asphalt until the surface has been cleaned as required and the section has been approved. Apply asphalt with a pressure distributor in a uniform, continuous spread over the section to be treated and within the temperature range specified. Design and field-verify the quantity of asphalt to be used per square yard. A preliminary asphalt application of from 0.05 to 0.10 gallon per square yard of surface may be required by the Engineer if the texture of the surface allows asphalt to penetrate too rapidly.

Use a strip of building paper at least 3 feet wide and as long as the spray bar of the distributor plus 1 foot at the beginning of each spread. Paper may be required at the end of each spread if the cutoff is not clean. Remove and dispose of the paper in a satisfactory manner. Ensure the distributor is moving forward at the proper application speed when the spray bar is opened. Correct skipped areas or deficiencies. Carefully mark junctions of spreads to ensure a smooth riding surface.

Do not expose asphalt for more than 1 minute before applying cover coat material. Limit the asphalt spread to the area that the trucks loaded with cover coat material can immediately cover.

The Department will allow meet-lines within 1 foot of lane lines or within 1 foot of center of lanes only. Meet lines are not allowed within a wheel path. Ensure transverse longitudinal joints are smooth and match the adjacent surfaces.

Do not spread asphalt more than 6 inches wider than the width covered by the cover coat material from the spreading device. Do not allow the asphalt to chill, set up, dry, or otherwise impair retention of the cover coat material.

When not spreading, park the distributor so that the spray bar or mechanism will not drip on the roadway surface when not spreading.

Spread cover coat material at the designed and field-verified rate immediately following the application of asphalt. Do not allow the tires of the trucks or aggregate spreader to contact the uncovered asphalt. Do not allow pilot car traffic control operations to cross the fresh asphalt meet-line onto newly applied cover coat material.

Moisten aggregate stockpiles with water 12 to 24 hours before placement to eliminate or reduce the dust coating of the aggregate.

Cover deficient areas with additional approved material immediately after the cover coat material is spread. Begin rolling immediately behind the spreading operation and continue until 3 complete coverages are obtained. Complete rolling within 5 minutes of spreading cover coat material and before allowing traffic to use the new surface. If choke sand is specified, the following applies:

1. Immediately after the third roller pass, apply choke sand to the entire roadway surface at a rate of 4 pounds per square yard or as directed.
2. Do not "tailgate" or use a spinner when applying choke sand.

Do not operate equipment at a speed that turns or displaces the cover coat material. The Engineer may require applying approved reject material over the surface to absorb any free asphalt before brooming. Sweep excess material from the entire roadway surface with rotary brooms. Complete the initial brooming by the morning following the previous day's chip seal application unless otherwise directed. Do not displace embedded material when brooming. Pickup excess material in curb and gutter sections and dispose of as directed.

Perform second brooming approximately 24 hours after the first brooming and after traffic has been routed on the chip sealed roadway, when required.

Provide brooms that are in good condition and capable of sweeping a path at least 70 inches wide without loosening or displacing embedded materials.

Accompany each broom by a shadow vehicle if working on highways open to traffic. Equip the shadow vehicle with at least 1 roof-mounted high-intensity rotating or strobe-type amber flasher that is readily visible from front and rear for one-half mile.

Lightly spray the surface of the roadway with enough water to prevent dust from becoming airborne when brooming operations could create dust to the extent that it would violate air pollution regulations or create a safety hazard.

Keep the highway open to traffic. The Contractor may route controlled traffic on the surface treatment as soon as the asphalt is covered.

Maintain the first chip seal and allow it to cure for 5 calendar days if successive chip seals are to be applied.

The Department will allow meet-lines within 1 foot of lane lines or within 1 foot of center of lanes only. Meet lines are not allowed within a wheel path. Ensure transverse longitudinal joints are smooth and match the adjacent surfaces.

Do not spread asphalt more than 6 inches wider than the width covered by the cover coat material from the spreading device. Do not allow the asphalt to chill, set up, dry, or otherwise impair retention of the cover coat material.

When not spreading, park the distributor so that the spray bar or mechanism will not drip on the roadway surface when not spreading.

Spread cover coat material at the designed and field-verified rate immediately following the application of asphalt. Do not allow the tires of the trucks or aggregate spreader to contact the uncovered asphalt. Do not allow pilot car traffic control operations to cross the fresh asphalt meet-line onto newly applied cover coat material.

Moisten aggregate stockpiles with water 12 to 24 hours before placement to eliminate or reduce the dust coating of the aggregate.

Cover deficient areas with additional approved material immediately after the cover coat material is spread. Begin rolling immediately behind the spreading operation and continue until 3 complete coverages are obtained. Complete rolling within 5 minutes of spreading cover coat material and before allowing traffic to use the new surface. If choke sand is specified, the following applies:

1. Immediately after the third roller pass, apply choke sand to the entire roadway surface at a rate of 4 pounds per square yard or as directed.
2. Do not "tailgate" or use a spinner when applying choke sand.

Do not operate equipment at a speed that turns or displaces the cover coat material. The Engineer may require applying approved reject material over the surface to absorb any free asphalt before brooming. Sweep excess material from the entire roadway surface with rotary brooms. Complete the initial brooming by the morning following the previous day's chip seal application unless otherwise directed. Do not displace embedded material when brooming. Pickup excess material in curb and gutter sections and dispose of as directed.

Perform second brooming approximately 24 hours after the first brooming and after traffic has been routed on the chip sealed roadway, when required.

Provide brooms that are in good condition and capable of sweeping a path at least 70 inches wide without loosening or displacing embedded materials.

Accompany each broom by a shadow vehicle if working on highways open to traffic. Equip the shadow vehicle with at least 1 roof-mounted high-intensity rotating or strobe-type amber flasher that is readily visible from front and rear for one-half mile.

Lightly spray the surface of the roadway with enough water to prevent dust from becoming airborne when brooming operations could create dust to the extent that it would violate air pollution regulations or create a safety hazard.

Keep the highway open to traffic. The Contractor may route controlled traffic on the surface treatment as soon as the asphalt is covered.

Maintain the first chip seal and allow it to cure for 5 calendar days if successive chip seals are to be applied.

What Is This Study All About?

- ▶ The Transportation Pooled Funding program (TPF) was first defined in 1977, per Title 23 Code of Federal Regulations (CFR) § 560.3, as a Federal Highway Administration (FHWA) administered program in coordination with State departments of transportation (DOT).
- ▶ TPF program creates an opportunity for partners to pool their funds, subject matter expertise, and resources to conduct high-priority research. As part of the Transportation Pooled Funding (TPF) program, TPF-5(522) (commonly known as PG3) was created and awarded to a National Partnership to Improve the Quality of Pavement Preservation Treatment Construction & Data Collection Practices.
- ▶ PG1 was to construct the Lee County Road 59 and US 280 test sites near NCAT.
- ▶ PG2 was to construct the Minnesota test facility.
- ▶ National Partnership consist of MnDOT, NCPP, FP2, NCAT, and essentially each participating State.

What Is This Study All About?

- ▶ The pooled fund is focused on implementation of pavement preservation treatment implementation. There are 19 states involved. As each state selects and applies a treatment, there is preconstruction review of the State's specifications by both the NCPP and the FP2.
 - ▶ This MnDOT project will be placing a Scrub Cape Seal on US 71, as part of the PG3. At time of construction, representatives from NCPP and FP2 will be on-site for additional training on equipment calibration, application rates, material testing/sampling, inspection and what to look for in good treatment construction. There will be test cells for long term monitoring of performance.
- 

Scheduling of Test Cell Construction

- ▶ NCPP Preservation Specialists and / or industry volunteers must be on site for Test Cell construction.
- ▶ The Agency and Contractor shall provide the following notices to the NCPP Representative.
 - 14-days' notice of anticipated Test Cell construction date.
 - 5-day schedule review.

Scheduling of Test Cell Construction

▶ 48-hour Go / No Go

- It is understood that this is construction and things happen. If the representative arrives on site and Test Cell construction is delayed due to weather, equipment or materials a decision will be made to hold or return at a later date

Scheduling of Test Cell Construction

- ▶ It is preferable but not required that Test Cell construction be completed during weekday day-time hours.
 - ▶ Test cell details shall be approved by PG3 Data Team prior to scheduling Test Cell construction.
 - ▶ Contractor shall provide unlimited access to equipment, calibration information, mix designs, supervisors and crew members for recordkeeping and training purposes.
- 

Test Cell Construction – Responsibilities

- ▶ Agency shall designate at least one on-site individual to assist in the RECORD KEEPING process.
 - ▶ Data forms will be provided by NCPP
 - ▶ Meet specifications and best practices
 - ▶ The Agency shall be responsible for all field data retention and storage.
 - ▶ The data shall be shared with the Pool Study team (MnDOT, NCPP, NCAT) in a common protocol.
- 

Test Cell Construction – Responsibilities

- ▶ Record keeping
- ▶ There are 2 forms that need to be completed for the Chip Seal Test Section
 - ▶ Preconstruction
 - ▶ Construction

Test Cell Construction – Responsibilities

▶ NCPP

- Equipment Review
 - Material and Stockpile Review
 - Discussion of Best Practices with crew and inspectors
 - Assist agency with completion of Data Form
 - Completion of “After Action Review” of Test Cell Construction.
- 

Test Cell Construction – Responsibilities

▶ Contractor

- Provide access to equipment, employees and materials
 - Perform work that meets project specification and industry best practices.
 - Assist in gathering data.
- 

Test Cell Construction – Responsibilities

▶ Industry Volunteers

- Assist NCPP with gathering project data.
- Take photos and/or videos and provide to NCPP.
- Review project in post PG3 years

Test Cell Layout

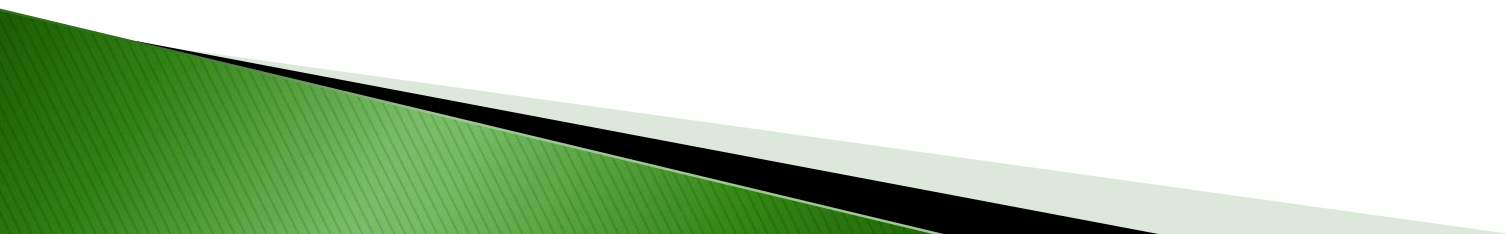

Preconstruction and Construction Forms



Chip Seal Pre-Construction

Form	Scrub Seal Construction Data Sheet	
Project	Location Description	
Section	Section if multiple variations	
Owner	Agency	
Design Information		
1	TYPE OF BINDER	Dropdown (Asphalt Emulsion/Hot Applied)
2	DESIGN METHOD USED	Dropdown (McCleod/Kirby/Other Specify in Comment)
3	DESIGN METHOD COMMENTS	Text
4	APPLICATION RATE FOR BITUMINOUS MATERIAL	Gallons/SYD
5	APPLICATION RATE FOR AGGREGATE	Pounds/SYD
6	MATERIAL TEST RESULTS	Attached Sheet
General Condition Information		
7	PRIMARY DISTRESS	Dropdown?
8	PRIMARY DISTRESS SEVERITY	LTPP Severity
9	PRIMARY DISTRESS EXTENT	LTPP Extent
10	SECONDARY DISTRESS	Dropdown?
11	SECONDARY DISTRESS SEVERITY	LTPP Severity
12	SECONDARY DISTRESS EXTENT	LTPP Extent
13	DISTRESS COMMENTS	Text
14	CRACK SEALED?	Dropdown (Yes/No)
15	CRACK SEAL MATERIAL	Text
16	CRACK SEAL DATE	dd/mm/yy

Chip Seal Construction

Form	Scrub Seal Construction Data Sheet	
Project	Location Description	
Section	Section if multiple variations	
Owner	Agency	
Item	Description	Data
1	LAYER NUMBER (From Data Sheet XX)	Numeric
2	DATE SEALING BEGAN	dd/mm/yy
3	DATE SEALING COMPLETE	dd/mm/yy
Surface Preparation		
4	PAVEMENT SURFACE PREPARATION	Dropdown (Sweep/Micro Mill/None/Other Describe in Comment)
5	PAVEMENT SURFACE PREPARATION COMMENT	Text
6	EXISTING PAVEMENT MARKING TREATMENT	Dropdown (Total Removal/Fog/None/Other Describe in Comment)
7	EXISTING PAVEMENT MARKING TREATMENT COMMENT	Text
Ambient Conditions at Time of Placement		
8	SURFACE MOISTURE AT PLACEMENT	Dropdown (Dry/Damp)
9	AIR TEMPERATURE (°F)	Numeric
10	SURFACE TEMPERATURE (°F)	Numeric
11	RELATIVE HUMIDITY (%)	Numeric
12	CLOUD COVER (%)	Numeric
13	WIND SPEED (MPH)	Numeric

Chip Seal Construction

Equipment Information		
14	NUMBER OF ASPHALT DISTRIBUTORS ON PROJECT	Numeric
15	DISTRIBUTORS CALIBRATED?	Dropdown (Yes/No)
16	DISTRIBUTORS CALIBRATION DATE	dd/mm/yy
17	DISTRIBUTORS CALIBRATION COMMENTS/DOCUMENTATION	Text
18	DISTRIBUTOR #1 MANUFACTURER/MODEL	Text
19	DISTRIBUTOR #1 NOZZLE ANGLE (degrees)	Numeric
20	DISTRIBUTOR #1 SPRAY BAR HEIGHT (inches)	Numeric
21	DISTRIBUTOR #1 NOZZLE SPACING (inches)	Numeric
22	DISTRIBUTOR #1 NOZZLE BRAND/MODEL	Text
23	DISTRIBUTOR #2 MANUFACTURER/MODEL	Text
24	DISTRIBUTOR #2 NOZZLE ANGLE (degrees)	Numeric
25	DISTRIBUTOR #2 SPRAY BAR HEIGHT (inches)	Numeric
26	DISTRIBUTOR #2 NOZZLE SPACING (inches)	Numeric
27	DISTRIBUTOR #2 NOZZLE BRAND/MODEL	Text
28	DISTRIBUTOR #3 MANUFACTURER/MODEL	Text

Chip Seal Construction

Equipment Information		
14	NUMBER OF ASPHALT DISTRIBUTORS ON PROJECT	Numeric
15	DISTRIBUTORS CALIBRATED?	Dropdown (Yes/No)
16	DISTRIBUTORS CALIBRATION DATE	dd/mm/yy
17	DISTRIBUTORS CALIBRATION COMMENTS/DOCUMENTATION	Text
18	DISTRIBUTOR #1 MANUFACTURER/MODEL	Text
19	DISTRIBUTOR #1 NOZZLE ANGLE (degrees)	Numeric
20	DISTRIBUTOR #1 SPRAY BAR HEIGHT (inches)	Numeric
21	DISTRIBUTOR #1 NOZZLE SPACING (inches)	Numeric
22	DISTRIBUTOR #1 NOZZLE BRAND/MODEL	Text
23	DISTRIBUTOR #2 MANUFACTURER/MODEL	Text
24	DISTRIBUTOR #2 NOZZLE ANGLE (degrees)	Numeric
25	DISTRIBUTOR #2 SPRAY BAR HEIGHT (inches)	Numeric
26	DISTRIBUTOR #2 NOZZLE SPACING (inches)	Numeric
27	DISTRIBUTOR #2 NOZZLE BRAND/MODEL	Text
28	DISTRIBUTOR #3 MANUFACTURER/MODEL	Text

Chip Seal Construction

43	PNEUMATIC ROLLER #2 TONS	Numeric
44	PNEUMATIC ROLLER #2 TIRE PRESSURE (PSI)	Numeric
45	PNEUMATIC ROLLER #3 MANUFACTURER/MODEL	Text
46	PNEUMATIC ROLLER #3 TONS	Numeric
47	PNEUMATIC ROLLER #3 TIRE PRESSURE (PSI)	Numeric
48	PNEUMATIC ROLLER #4 MANUFACTURER/MODEL	Text
49	PNEUMATIC ROLLER #4 TONS	Numeric
50	PNEUMATIC ROLLER #4 TIRE PRESSURE (PSI)	Numeric
51	PNEUMATIC ROLLER COMMENTS	Text
52	NUMBER OF POWER BROOMS ON PROJECT	Numeric
53	BROOM #1 MANUFACTURER/MODEL	Text
54	BROOM #2 MANUFACTURER/MODEL	Text
55	BROOM #3 MANUFACTURER/MODEL	Text
56	BROOM #4 MANUFACTURER/MODEL	Text
57	BROOM COMMENTS	Text
Material Information		
58	AGGREGATE SOURCE	Text
59	AGGREGATE TYPE	Text
60	AGGREGATE PRE-COATED?	Dropdown (Yes/No)
61	AGGREGATE MOISTURE	Dropdown (Dry/Damp)
62	AGGREGATE APPLICATION RATE (LB/SYD)	Numeric
63	CHIP BINDER SOURCE	Text

Chip Seal Construction

64	CHIP BINDER TYPE	Text
65	CHIP BINDER APPLICATION RATE (Gal/SYD)	Text
66	FOG BINDER SOURCE	Text
67	FOG BINDER TYPE	Text
68	CHIP BINDER APPLICATION RATE (Gal/SYD)	Numeric
Construction Information		
69	TIME FROM BINDER APPLICATION TO AGGREGATE APPLICATION	Numeric
70	TIME FROM AGGREGATE APPLICATION TO FIRST ROLLER PASS	Numeric
71	NUMBER OF PNEUMATIC ROLLER PASSES	Numeric
72	AGGREGATE APPLICATION RATE CHECK #1	Pounds/SYD
73	AGGREGATE APPLICATION RATE CHECK #1 COMMENT	Text
74	AGGREGATE APPLICATION RATE CHECK #2	Pounds/SYD
75	AGGREGATE APPLICATION RATE CHECK #2 COMMENT	Text
76	BINDER APPLICATION RATE CHECK #1	Gallons/SYD
77	BINDER APPLICATION RATE CHECK #1 COMMENT	Text
78	BINDER APPLICATION RATE CHECK #2	Gallons/SYD
79	BINDER APPLICATION RATE CHECK #2 COMMENT	Text
80	TIME FROM PLACEMENT TO OPENING TO TRAFFIC	Numeric
81	TIME FROM PLACEMENT TO INITIAL BROOMING	Numeric
82	FOG SEAL DATE	dd/mm/yy/NA

Chip Seal Construction

Test Cell Information		
83	CURE TIME (OPEN TO ROLLING TRAFFIC)	Hours/Minutes
84	AGGREGATE APPLICATION RATE	Pounds/SYD
85	CHIP EMULSION APPLICATION RATE	Gallons/SYD
86	FOG EMULSION APPLICATION RATE	Gallons/SYD

Chip Seal Materials Test Form

Form	Chip Seal Material Test Results	
Aggregate Tests		
Gradation		
	Sieve	% Passing
	1/2"	
	3/8"	
	1/4"	
	#4	
	#8	
	#16	
	#50	
	#200	
	Decant	
Bulk Specific Gravity		
Loose Unit Weight		lb/ft ³
Aggregate Absorption		%
Flakiness Index		%



**Questions or
Comments ?**

Thank You!

Rex W. Eberly
Training Specialist
National Center for Pavement
Preservation

eberlyre@msu.edu

785-819-1403

