

ALDOT's PG3 Cape Seal Project

(Scrub Seal and Micro Surfacing)

By Mark Waits

NCPP



MICHIGAN STATE
UNIVERSITY

Best Practices for *Scrub Seal* Applications



MICHIGAN STATE
UNIVERSITY

What is pavement preservation?

- When the right treatment is applied to the right road at the right time, roads can be kept in good condition instead of performing costly rehabilitation and reconstruction alternatives later in the pavement's life when the structure has deteriorated.

Source: National Center for Asphalt Technology (NCAT) at Auburn University.



MICHIGAN STATE
UNIVERSITY

Pavement Preservation Scrub Seal in early 1900



Pavement Preservation Micro Surfacing in China



Pavement Preservation

Created By: Chris Soria

Copyright © Black Diamond Paving



**BLACK DIAMOND
PAVING**

PAVEMENT LIFE CYCLE

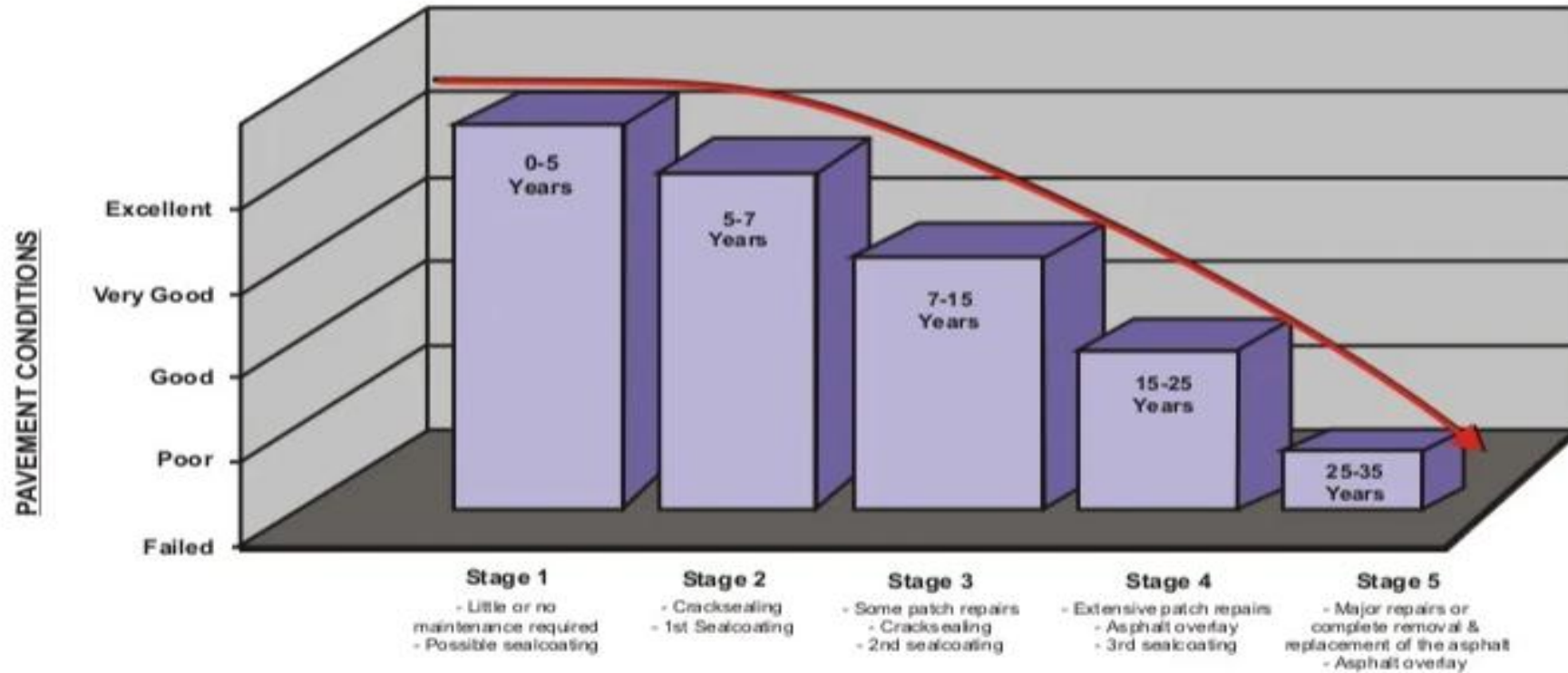

www.BlackDiamondPaving.com
Ph: (510) 770-1150
Fax: (510) 770-1151

PAVEMENT MAINTENANCE PROCEDURE BY STAGE

Black Diamond Paving
41550 Boscell Road
Fremont CA 94538

Time for Scrub or Micro?

Created By: Chris Soria

Copyright © Black Diamond Paving

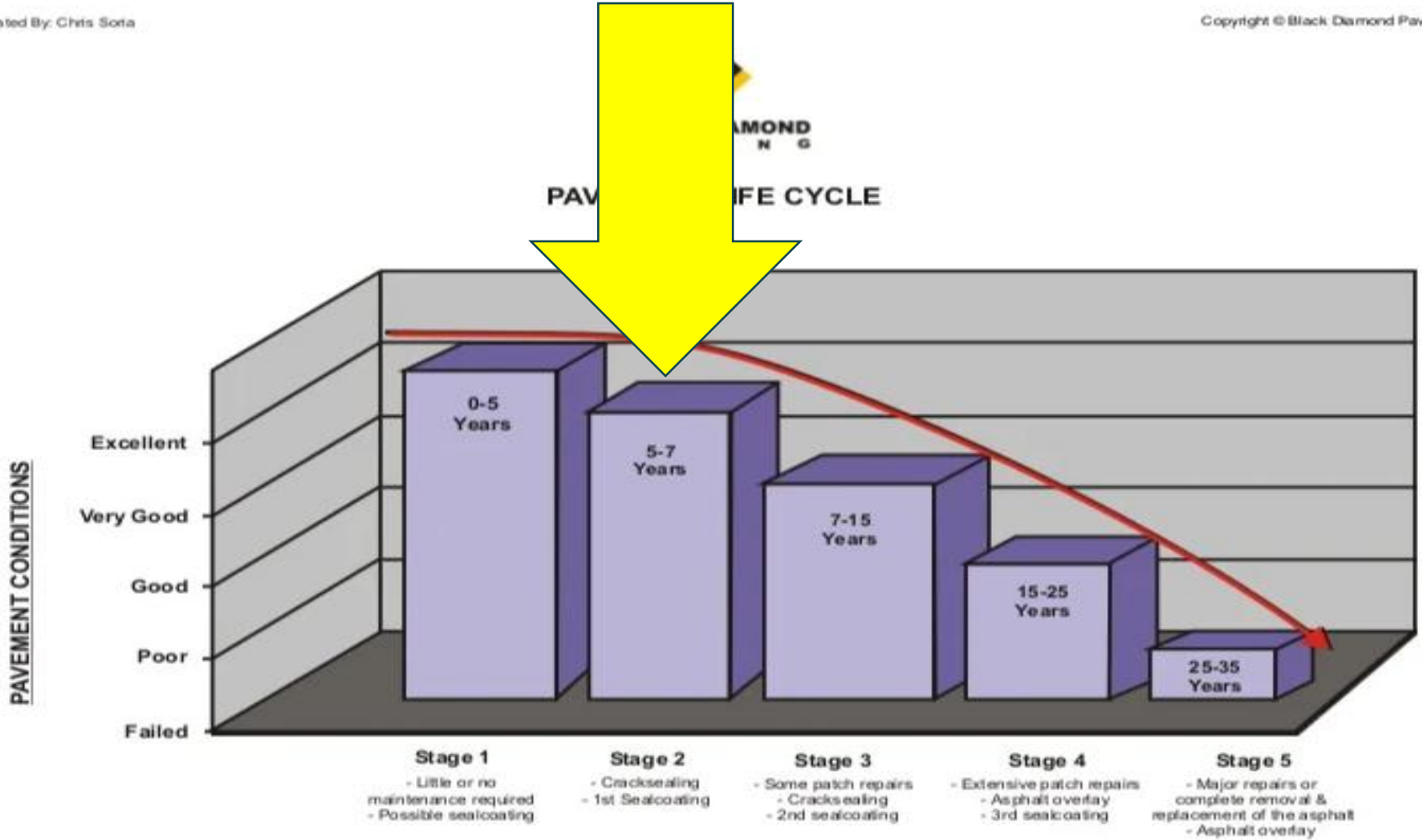

FY 2019 – FY 2022 Overview

Amount spent on **IM** preservation projects

- **24%** of the \$587.7m used for IM Pavement management, from 2019-2022, was spent on **PM1**

IM Resurfacing FY 2019 - FY2022				
	PM 1	PM 2	MR	total
FY 2019	11	4	6	21
Amount Spent	\$40.60	\$46.10	\$92	\$178.70
FY 2020	7	6	6	20
Amount Spent	\$41.20	\$41.90	\$67.40	\$150.50
FY 2021	6	5	3	14
Amount Spent	\$26.50	\$54.60	\$42.30	\$123.40
FY 2022	8	8	2	18
Amount Spent	\$32.10	\$56.90	\$46.10	\$135.10
Total:	32	23	17	\$587.70

FY 2019 – FY 2022 Overview

Amount spent on IM preservation projects

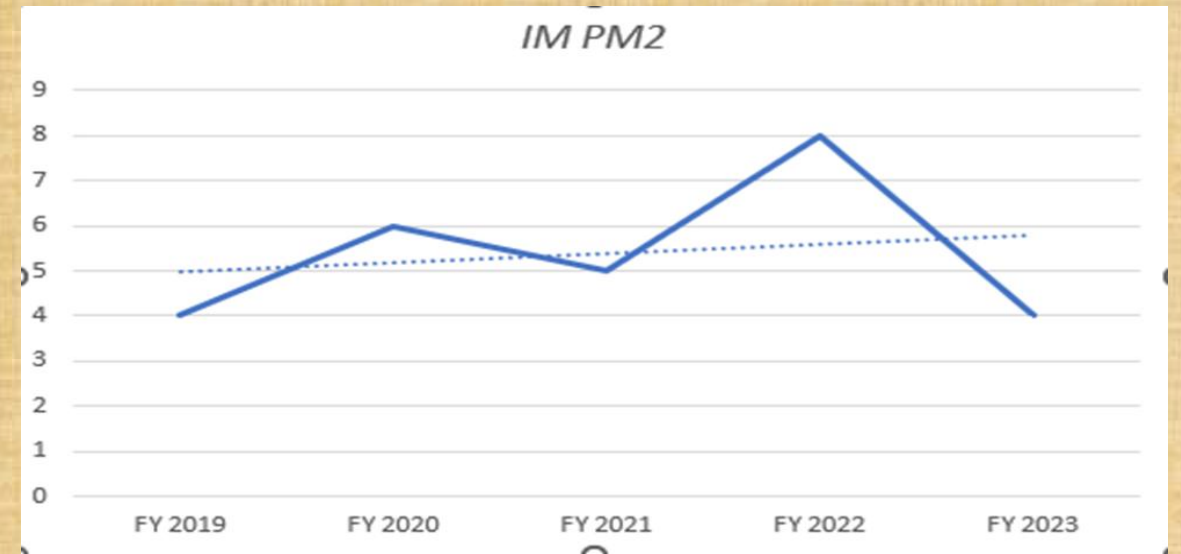
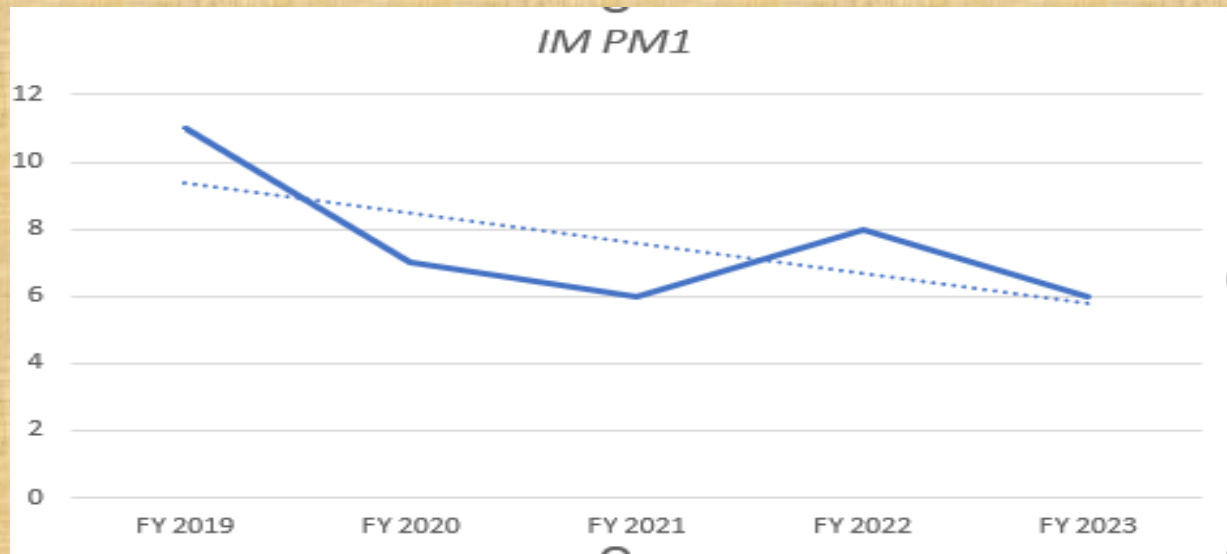

Impact of 2017 PP Training

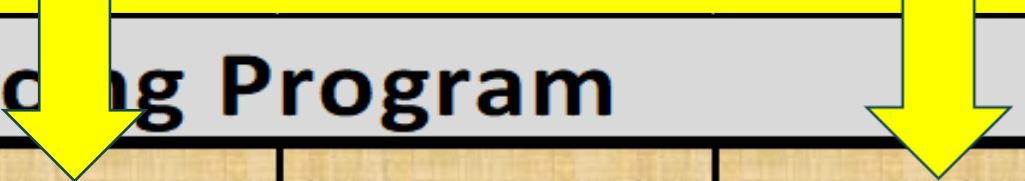

FM Resurfacing Program			
	PM 1	PM 2	MR
FY 2019	7	55	45
FY 2020	10	76	19
FY 2021	15	70	24
FY 2022	11	72	14
FY 2023	9	63	20

- **Impact of 2017 PP Training**

- ***Time for training again?***

FM Resurfacing Program

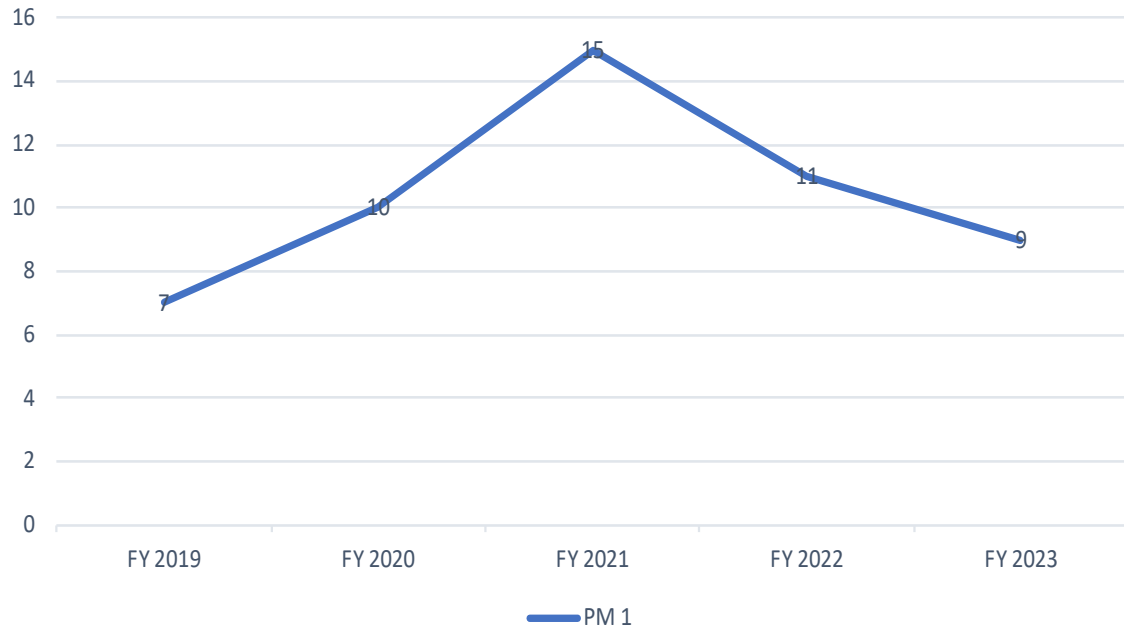

MR

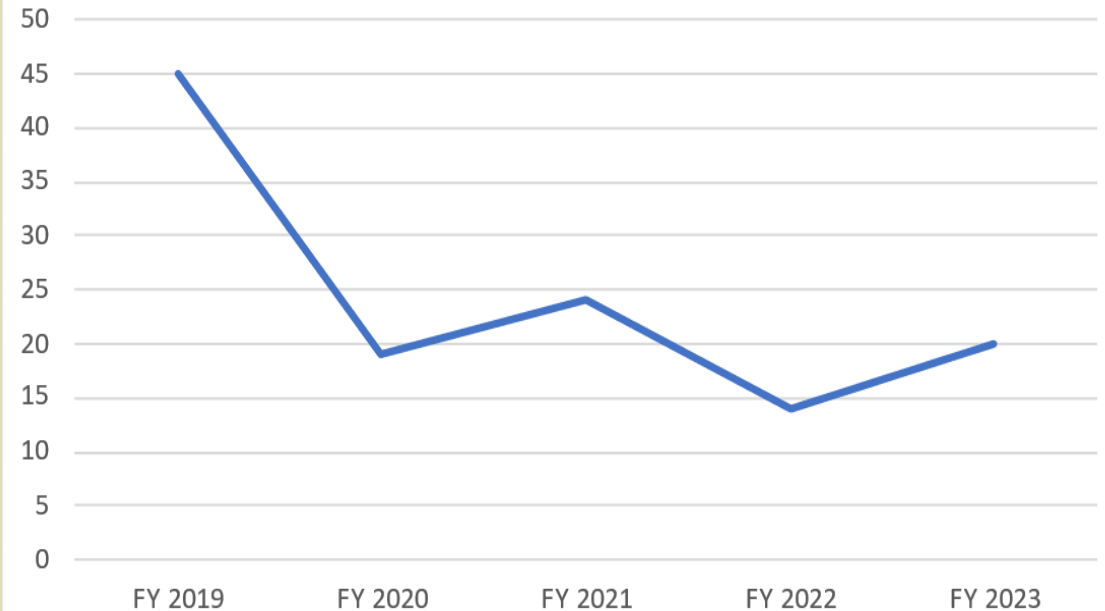

WHY PAVEMENT PRESERVATION?

States with the worst (and best) road conditions

Updated 21 February 2025



Whether you're one to take the road less traveled or are more prone to thinking that "life is a highway," chances are you've hit at least a few potholes over the years. Depending on where you live, poor road conditions may be an occasional inconvenience or a daily frustration. Either way, they accelerate wear and tear on your car, leading to costly repairs that may not be covered by an [extended auto warranty](#).

In fact, the [American Society of Civil Engineers](#) estimates that nationwide, drivers spend a whopping \$130 billion each year on extra vehicle repairs and operating costs because of deteriorating roads. The price tag for poor-quality roadways doesn't stop there: the U.S. has a backlog of approximately \$435 billion in projects to repair existing roads, and by 2040, rising temperatures are expected to add an estimated \$19 billion each year to pavement repair costs. But where are our roads the roughest?

The ConsumerAffairs Research Team identified the states with the worst roads by analyzing metrics including rural and urban road roughness and traffic fatalities. Read on to see how we conducted our analysis.



[Cite](#) [Download PDF](#)

WRITING AN ARTICLE?
Get a quote from us to

Outline [Figures \(2\)](#)

[States with the worst road](#)

[States with the best road](#)

[Full data](#)

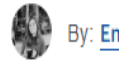

By: [En](#)

2. Alabama

Alabama ranks second in overall road conditions, with 96.5% of its urban roads and 98.7% of its rural roads in acceptable condition. This strong road quality aligns with ongoing infrastructure investments, including the Rebuild Alabama Act, which has generated \$320 million annually for road and bridge improvements since 2019.

In 2024, Gov. Kay Ivey announced over \$40 million in additional state funding through the ATRIP-II program, supporting infrastructure projects across Alabama. These continued investments contribute to the state's ability to maintain its extensive road network.

Check out these metrics:

- **Percentage of urban roads in poor condition:** 3.5%
- **Percentage of rural roads in poor condition:** 1.3%
- **Traffic fatalities per 100M miles traveled:** 1.38

What Is A Scrub Seal?



What is a Scrub Seal?

Rejuvenating Scrub Seal

A scrub seal is an application that is very similar to a *Chip Seal* treatment. The only difference is that the asphalt distributor pulls a **broom sled** that houses a series of brooms placed at different angles. These brooms guide or "scrub" the emulsion into narrow cracks that ensure the road will be sealed.



Chip Seal

Bituminous Seal Coat is essentially a single layer of asphalt binder that is covered by embedded aggregate *(one stone thick)* whose primary purpose is to seal the fine cracks in an underlying pavement's surface and prevent water intrusion into the base and subgrade.

Chip Seal

Bituminous Seal Coat is essentially a single layer of asphalt binder that is covered by embedded aggregate (*one stone thick*) whose primary purpose is to seal the fine cracks in an underlying pavement's surface and prevent water intrusion into the base and subgrade.



Chip Seal Selection

Good Candidates



Minor Cracking



Loss of Fines



Flushing



Oxidation



Loss of Friction

Chip Seal Selection

Unacceptable Candidates



Rutted Pavement



Poor Ride

Chip Seal Selection

Unacceptable Candidates



Cracks $>3/4$ "



Structural Issues

Chip Seal Selection

Unacceptable Candidate
Low Severity Fatigue Cracking



Chip Seal

The main advantages of chip seals include:

- *Improved Skid Resistance*: Chip seals provide good skid resistance,
- *Cost Effective Treatments*: Chip seals are typically cost effective when properly placed on the right type of pavement,
- *Good Durability*: By using durable aggregates, chip seals wear well and can have long service lives,
- *Ease of Construction*: Chip seals are typically constructed rapidly and cause less disruption to the traveling public.

Chip Seal

The main advantages of chip seals include:

- ***Improved Skid Resistance: Chip seals provide good skid resistance,***
- **Cost Effective Treatments:** Chip seals are typically cost effective when properly placed on the right type of pavement,
- **Good Durability:** By using durable aggregates, chip seals wear well and can have long service lives,
- **Ease of Construction:** Chip seals are typically constructed rapidly and cause less disruption to the traveling public.

Chip Seal

The main advantages of chip seals include:

- Improved Skid Resistance: Chip seals provide good skid resistance,
- ***Cost Effective Treatments: Chip seals are typically cost effective when properly placed on the right type of pavement,***
- **Good Durability:** By using durable aggregates, chip seals wear well and can have long service lives,
- **Ease of Construction:** Chip seals are typically constructed rapidly and cause less disruption to the traveling public.

Chip Seal

The main advantages of chip seals include:

- Improved Skid Resistance: Chip seals provide good skid resistance,
 - Cost Effective Treatments: Chip seals are typically cost effective when properly placed on the right type of pavement,
 - ***Good Durability: By using durable aggregates, chip seals wear well and can have long service lives,***
 - Ease of Construction: Chip seals are typically constructed rapidly and cause less disruption to the traveling public.
- 

Chip Seal

The main advantages of chip seals include:

- Improved Skid Resistance: Chip seals provide good skid resistance,
- Cost Effective Treatments: Chip seals are typically cost effective when properly placed on the right type of pavement,
- Good Durability: By using durable aggregates, chip seals wear well and can have long service lives,
- ***Ease of Construction: Chip seals are typically constructed rapidly and cause less disruption to the traveling public.***

Chip Seal

- ***Chip Seals help preserve the pavement by:***
 - Protecting the surface asphalt from oxidation.
 - Oxidation, caused by sun and chemicals make the asphalt cement brittle and more prone to cracking and raveling.
 - Protecting the surface and base from moisture intrusion.
 - Moisture causes:
 - Stripping of base layers
 - Potholes
 - Base Failures
 - Repairing light raveling
 - As asphalt ages, top layer gets brittle
 - Small aggregate begins to wear away
 - Seal coat adds new binder to halt this
 - Provides a skid resistant, sacrificial wearing surface that protects the underlying surface from traffic wear and damage.

Chip Seal

- *Chip Seals help preserve the pavement by:*
 - ***Protecting the surface asphalt from oxidation.***
 - Oxidation, caused by sun and chemicals make the asphalt cement brittle and more prone to cracking and raveling.
 - Protecting the surface and base from moisture intrusion.
 - Moisture causes:
 - Stripping of base layers
 - Potholes
 - Base Failures
 - Repairing light raveling
 - As asphalt ages, top layer gets brittle
 - Small aggregate begins to wear away
 - Seal coat adds new binder to halt this
 - Provides a skid resistant, sacrificial wearing surface that protects the underlying surface from traffic wear and damage.

Chip Seal

- ***Chip Seals help preserve the pavement by:***
 - *Protecting the surface asphalt from oxidation.*
 - Oxidation, caused by sun and chemicals make the asphalt cement brittle and more prone to cracking and raveling.
 - ***Protecting the surface and base from moisture intrusion.***
 - ***Moisture causes:***
 - ***Stripping of base layers***
 - ***Potholes***
 - ***Base Failures***
 - Repairing light raveling
 - As asphalt ages, top layer gets brittle
 - Small aggregate begins to wear away
 - Seal coat adds new binder to halt this
 - Provides a skid resistant, sacrificial wearing surface that protects the underlying surface from traffic wear and damage.

Chip Seal

- ***Chip Seals help preserve the pavement by:***
 - *Protecting the surface asphalt from oxidation.*
 - Oxidation, caused by sun and chemicals make the asphalt cement brittle and more prone to cracking and raveling.
 - Protecting the surface and base from moisture intrusion.
 - Moisture causes:
 - Stripping of base layers
 - Potholes
 - Base Failures
- ***Repairing light raveling***
 - **As asphalt ages, top layer gets brittle**
 - **Small aggregate begins to wear away**
 - **Seal coat adds new binder to halt this**
- Provides a skid resistant, sacrificial wearing surface that protects the underlying surface from traffic wear and damage.

Chip Seal

- ***Chip Seals help preserve the pavement by:***
 - *Protecting the surface asphalt from oxidation.*
 - Oxidation, caused by sun and chemicals make the asphalt cement brittle and more prone to cracking and raveling.
 - Protecting the surface and base from moisture intrusion.
 - Moisture causes:
 - Stripping of base layers
 - Potholes
 - Base Failures
 - *Repairing light raveling*
 - As asphalt ages, top layer gets brittle
 - Small aggregate begins to wear away
 - Seal coat adds new binder to halt this
- ***Provides a skid resistant, sacrificial wearing surface that protects the underlying surface from traffic wear and damage.***

Chip Seal

401.03 (b) Temperature and Weather Limitations For Placement Of Surface Treatments.

All bituminous treatments shall be applied in strict conformity with the following:

1. Weather.

Bituminous surface treatments shall not be placed on a wet surface or when the Engineer will not allow the placement due to existing unfavorable weather conditions. They shall not be placed when the temperature is expected to fall below freezing during the night regardless of daytime temperature, when the ground is frozen, or when the surface temperature is less than 32 °F {0 °C}. Bituminous Surface Treatment A (Prime Coat) shall not be placed when the air temperature is below 40 °F {4 °C}. ***All other bituminous surface treatments (B, C, D, etc.) shall not be placed when the air temperature is below 60 °F {15°C}.***

Chip Seal

Alabama Bituminous Surface Treatments 401

401.03 (e) Spreading and Embedding Aggregate.

- ▶ The size and amount of aggregate used shall be in accordance with provisions of Subarticle 401.01(b) for the type treatment required by the plans or proposal.
- ▶ Spreading of aggregate shall follow application of bituminous material as closely as practicable using mechanical aggregate spreaders; inaccessible areas shall be covered as directed.
- ▶ Sufficient aggregate to cover each distributor load, in loaded trucks along with an adequate crew of workmen equipped with brooms standing by, shall be at the site before bituminous application begins.
- ▶ Spreading of the aggregate shall begin and continue immediately behind the application of the bituminous material.
- ▶ However, if excessive rolling of the aggregate occurs during spreading, the Engineer may allow the chip spreader to delay slightly in order to hold aggregate rolling to a minimum.
- ▶ Rolling shall begin immediately behind the spreading operation. Sufficient rollers shall be furnished to ensure that the initial pass of the roller is made within five minutes of the spreading of the aggregate.
- ▶ Rolling shall be continuous, providing coverage of the entire area of treatment to ensure thorough embedment of the aggregate.
- ▶ Unless a sufficient number of rollers are in operation to complete the above requirement, the next load of bituminous material shall not be applied until the rolling of the previous application is completed.
- ▶ When the Engineer determines the aggregate has been thoroughly embedded, rolling shall cease and the Contractor shall, without delay, remove all excess aggregate from the treatment area.

Chip Seal

Alabama Bituminous Surface Treatments 401

401.03 (e) Spreading and Embedding Aggregate.

- ▶ The size and amount of aggregate used shall be in accordance with provisions of Subarticle 401.01 (b) for the type treatment required by the plans or proposal.
- ▶ Spreading of aggregate shall follow application of bituminous material as closely as practicable using mechanical aggregate spreaders; inaccessible areas shall be covered as directed.
- ▶ **Sufficient aggregate** to cover each distributor load, **in loaded trucks** along with an adequate crew of workmen equipped with brooms standing by, **shall be at the site before bituminous application begins.**
- ▶ Spreading of the aggregate shall begin and **continue immediately behind** the application of the bituminous material.
- ▶ However, **if excessive rolling** of the aggregate occurs during spreading, the Engineer may **allow the chip spreader to delay** slightly in order to hold aggregate rolling to a minimum.
- ▶ Rolling shall begin immediately behind the spreading operation. Sufficient rollers shall be furnished to ensure that the initial pass of the roller is made within five minutes of the spreading of the aggregate.
- ▶ Rolling shall be continuous, providing coverage of the entire area of treatment to ensure thorough embedment of the aggregate.
- ▶ Unless a sufficient number of rollers are in operation to complete the above requirement, the next load of bituminous material shall not be applied until the rolling of the previous application is completed.
- ▶ When the Engineer determines the aggregate has been thoroughly embedded, rolling shall cease and the Contractor shall, without delay, remove all excess aggregate from the treatment area.

Chip Seal

Alabama Bituminous Surface Treatments 401

401.03 (e) Spreading and Embedding Aggregate.

- ▶ The size and amount of aggregate used shall be in accordance with provisions of Subarticle 401.01(b) for the type treatment required by the plans or proposal.
- ▶ Spreading of aggregate shall follow application of bituminous material as closely as practicable using mechanical aggregate spreaders; inaccessible areas shall be covered as directed.
- ▶ Sufficient aggregate to cover each distributor load, in loaded trucks along with an adequate crew of workmen equipped with brooms standing by, shall be at the site before bituminous application begins.
- ▶ Spreading of the aggregate shall begin and continue immediately behind the application of the bituminous material.
- ▶ However, if excessive rolling of the aggregate occurs during spreading, the Engineer may allow the chip spreader to delay slightly in order to hold aggregate rolling to a minimum.
- ▶ Rolling ***shall begin immediately*** behind the spreading operation. Sufficient rollers shall be furnished to ensure that the initial pass of the roller is ***made within five minutes*** of the spreading of the aggregate.
- ▶ ***Rolling shall be continuous***, providing coverage of the entire area of treatment to ensure thorough embedment of the aggregate.
- ▶ Unless a sufficient number of rollers are in operation to complete the above requirement, the next load of bituminous material shall not be applied until the rolling of the previous application is completed.
- ▶ When the Engineer determines the aggregate has been thoroughly embedded, rolling shall cease and the Contractor shall, without delay, remove all excess aggregate from the treatment area.

Chip Seal

Alabama Bituminous Surface Treatments 401

401.03 (e) Spreading and Embedding Aggregate.

- ▶ The size and amount of aggregate used shall be in accordance with provisions of Subarticle 401.01(b) for the type treatment required by the plans or proposal.
- ▶ Spreading of aggregate shall follow application of bituminous material as closely as practicable using mechanical aggregate spreaders; inaccessible areas shall be covered as directed.
- ▶ Sufficient aggregate to cover each distributor load, in loaded trucks along with an adequate crew of workmen equipped with brooms standing by, shall be at the site before bituminous application begins.
- ▶ Spreading of the aggregate shall begin and continue immediately behind the application of the bituminous material.
- ▶ However, if excessive rolling of the aggregate occurs during spreading, the Engineer may allow the chip spreader to delay slightly in order to hold aggregate rolling to a minimum.
- ▶ Rolling shall begin immediately behind the spreading operation. Sufficient rollers shall be furnished to ensure that the initial pass of the roller is made within five minutes of the spreading of the aggregate.
- ▶ Rolling shall be continuous, providing coverage of the entire area of treatment to ensure thorough embedment of the aggregate.
- ▶ **Unless a sufficient number of rollers are in operation to complete the above requirement, the next load of bituminous material shall not be applied** until the rolling of the previous application is completed.
- ▶ When the Engineer determines the aggregate has been thoroughly embedded, rolling shall cease and the Contractor shall, without delay, remove all excess aggregate from the treatment area.

Benefits of Rejuvenating Scrub Seals

- ▶ The scrub brooms evenly spread the emulsion and push emulsion into the cracks.
- ▶ Polymer Modified Rejuvenating Emulsion (PMRE) softens the asphalt that has been hardened by oxidation. The penetrates the surface and fills narrow cracks acting as a mass crack filler.
- ▶ Chips are placed in a normal fashion.
- ▶ Overband cracks larger than 3/8"



How Scrub Seals Work

- Fills cracks and voids
- Rejuvenates existing asphalt
- Forms a reflective crack resistant membrane between existing pavements and future overlays or seals. This membrane is called a SAMI (stress absorbing membrane interlayer).

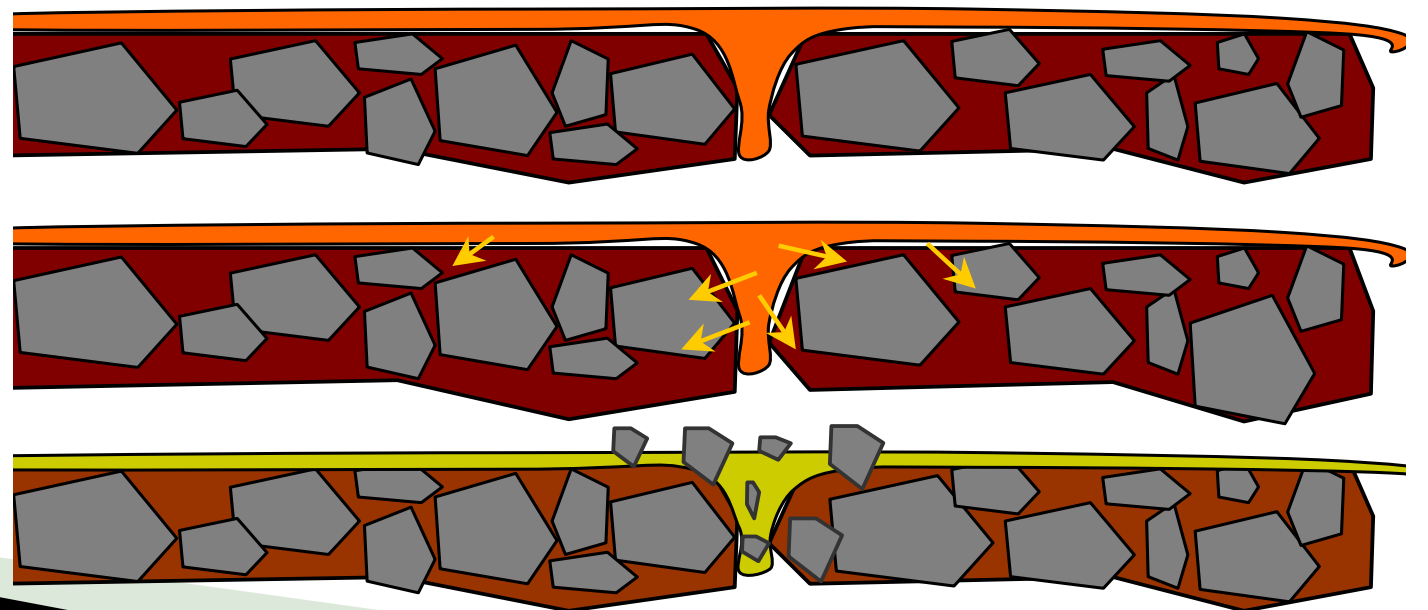

CORES



Scrub Seal



- Scrub Seal is a higher end Chip Seal that uses a broom trailer, pulled behind the distributor to spread and broom the asphalt emulsion into the fine ($< \frac{1}{4}$ "") surface cracks.
- Scrub Seal often uses PMRE, Polymer Modified Rejuvenating Emulsion to add life back into the surface and slow oxidation and crack growth.

Road Selection

To get a successful scrub seal, select roads that:

- have a sound structural section
- are in no need of repair

Isolated dig outs and crack sealing should be completed before the chip seal is applied (lead time varies depending on prep method).

What's a good candidate for a Scrub Seal Job?



Good Candidate



Good Candidate Continued



Primary Uses

Stand alone surface treatment

▶ **Mississippi HWY 35**



Primary Uses

Mass crack sealing treatment

- ▶ **Mass Crack Sealing**



Primary Uses

Combination Treatments



**Interlayer with
Micro over the top**

Interlayer with HMA





Mississippi Hwy 35
Scrub Seal =
Stand alone wearing course



Scrub Seal BOP

**Mississippi Hwy 35
Scrub Seal =
Stand alone wearing course**



Mississippi Hwy 35
Scrub Seal =
Stand alone wearing course





8 years untreated
shoulder



8 years treated
surface



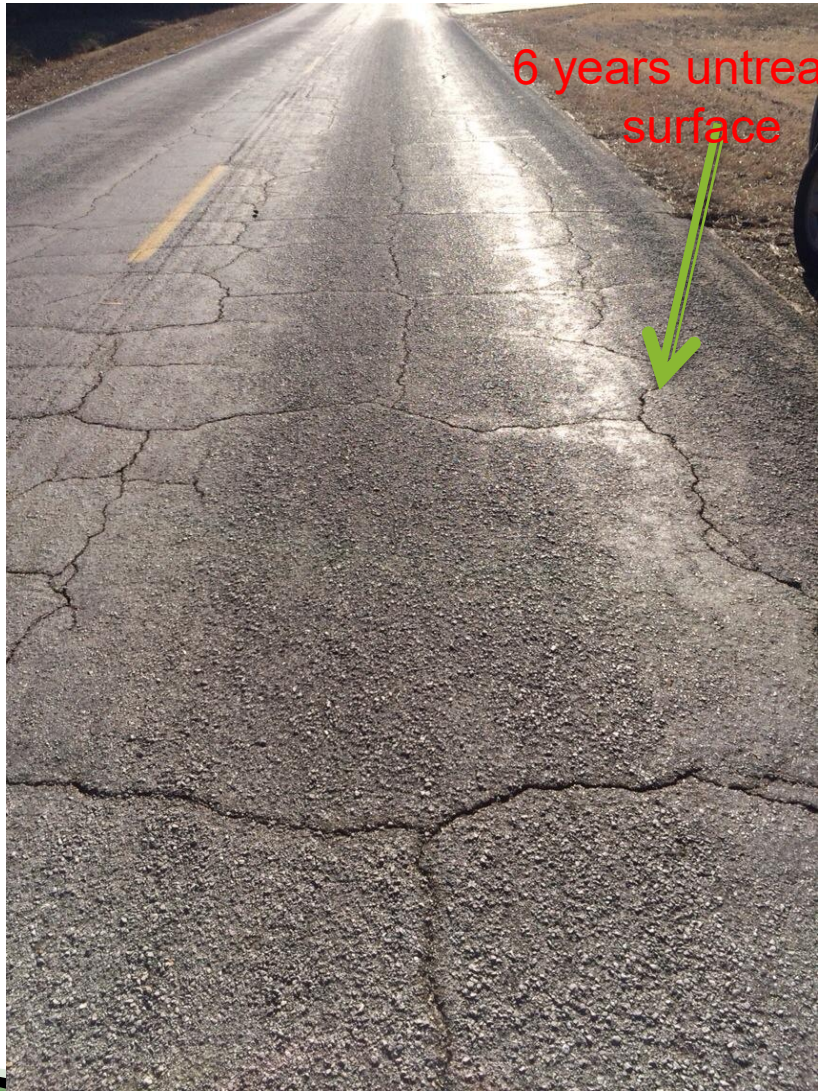

6 years untreated
surface



6 years treated
surface

Equipment

Equipment Placement



Rollers

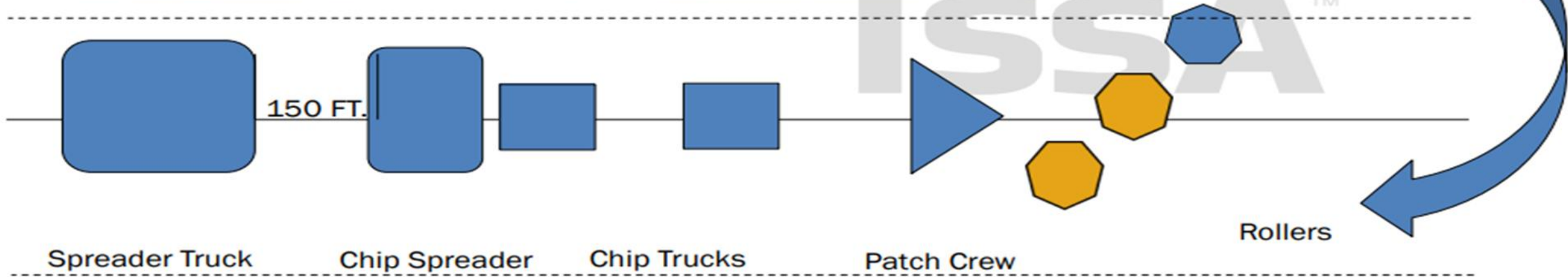

Sequence of a Scrub/Chip Seal Project

Equipment Placement

Road Preparation



Rollers

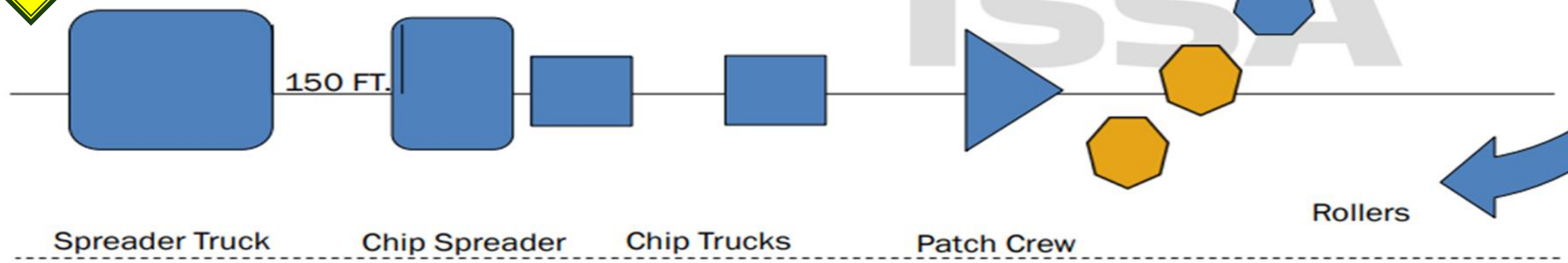

ISSATM

Road Preparation Checklist



Road Preparation Checklist

Alabama Bituminous Surface Treatments 401

401.03 (c) Preparation of Existing Surface. Loose material, dust, dirt, caked clay, or any foreign material shall be removed. Cleaning shall be continued until the surface is clean or, in case of application on a soil or aggregate surface, all the loose dirt is removed and the surfaces of the larger size aggregate in the road surface are exposed but not dislodged. All cleaning of the area to be treated shall be completed before any bituminous material is applied.

Road Preparation Checklist

Alabama Scrub Seal Section 433

433.03 (c) Surface Preparation.

- ▶ The area to be covered shall be dry to damp with no standing water and cleaned of dirt, vegetation, and dust and other deleterious materials prior to the application of the surfacing.
- ▶ On pavements where the scrub seal is to be the final layer, the Contractor shall remove all existing thermoplastic striping, markings, and legends flush with the surface within the scrub seal limits prior to the scrub seal operation.
- ▶ If a subsequent surface treatment or pavement layer will be placed over the scrub seal, removal of the existing thermoplastic may not be required.
- ▶ Prior to the scrub seal operation, the Contractor shall remove all raised pavement markers including any excessive adhesive left on the pavement caused from the removal of raised pavement markers.
- ▶ Prior to the scrub seal operation, all drain inlet covers, monument covers, and all other utility covers shall be protected from the Contractor's scrub seal operations by applying a sheet of plastic over the exposed facilities, or other methods approved by the Engineer.

Road Preparation Checklist

Alabama Scrub Seal Section 433

433.03 (c) Surface Preparation.

- ▶ **The area to be covered shall be dry to damp with no standing water and cleaned of dirt, vegetation, and dust and other deleterious materials prior to the application of the surfacing.**
- ▶ On pavements where the scrub seal is to be the final layer, the Contractor shall remove all existing thermoplastic striping, markings, and legends flush with the surface within the scrub seal limits prior to the scrub seal operation.
- ▶ If a subsequent surface treatment or pavement layer will be placed over the scrub seal, removal of the existing thermoplastic may not be required.
- ▶ Prior to the scrub seal operation, the Contractor shall remove all raised pavement markers including any excessive adhesive left on the pavement caused from the removal of raised pavement markers.
- ▶ Prior to the scrub seal operation, all drain inlet covers, monument covers, and all other utility covers shall be protected from the Contractor's scrub seal operations by applying a sheet of plastic over the exposed facilities, or other methods approved by the Engineer.

Road Preparation Checklist

Alabama Scrub Seal Section 433

433.03 (c) Surface Preparation.

- ▶ The area to be covered shall be dry to damp with no standing water and cleaned of dirt, vegetation, and dust and other deleterious materials prior to the application of the surfacing.
- ▶ **On pavements where the scrub seal is to be the final layer, the Contractor shall remove all existing thermoplastic striping, markings, and legends flush with the surface within the scrub seal limits prior to the scrub seal operation.**
- ▶ If a subsequent surface treatment or pavement layer will be placed over the scrub seal, removal of the existing thermoplastic may not be required.
- ▶ Prior to the scrub seal operation, the Contractor shall remove all raised pavement markers including any excessive adhesive left on the pavement caused from the removal of raised pavement markers.
- ▶ Prior to the scrub seal operation, all drain inlet covers, monument covers, and all other utility covers shall be protected from the Contractor's scrub seal operations by applying a sheet of plastic over the exposed facilities, or other methods approved by the Engineer.

Road Preparation Checklist

Alabama Scrub Seal Section 433

433.03 (c) Surface Preparation.

- ▶ The area to be covered shall be dry to damp with no standing water and cleaned of dirt, vegetation, and dust and other deleterious materials prior to the application of the surfacing.
- ▶ On pavements where the scrub seal is to be the final layer, the Contractor shall remove all existing thermoplastic striping, markings, and legends flush with the surface within the scrub seal limits prior to the scrub seal operation.
- ▶ If a **subsequent surface treatment** or pavement layer will be placed over the scrub seal, **removal of the existing thermoplastic may not be required.**
- ▶ Prior to the scrub seal operation, the Contractor shall remove all raised pavement markers including any excessive adhesive left on the pavement caused from the removal of raised pavement markers.
- ▶ Prior to the scrub seal operation, all drain inlet covers, monument covers, and all other utility covers shall be protected from the Contractor's scrub seal operations by applying a sheet of plastic over the exposed facilities, or other methods approved by the Engineer.

Road Preparation Checklist

Alabama Scrub Seal Section 433

433.03 (c) Surface Preparation.

- ▶ The area to be covered shall be dry to damp with no standing water and cleaned of dirt, vegetation, and dust and other deleterious materials prior to the application of the surfacing.
- ▶ On pavements where the scrub seal is to be the final layer, the Contractor shall remove all existing thermoplastic striping, markings, and legends flush with the surface within the scrub seal limits prior to the scrub seal operation.
- ▶ If a **subsequent surface treatment** or pavement layer will be placed over the scrub seal, **removal of the existing thermoplastic may not be required.**
- ▶ Prior to the scrub seal operation, the Contractor shall remove all raised pavement markers including any excessive adhesive left on the pavement caused from the removal of raised pavement markers.
- ▶ **Prior to** the scrub seal operation, all drain inlet covers, monument covers, and all other utility covers **shall be protected** from the Contractor's scrub seal operations by applying a sheet of plastic over the exposed facilities, or other methods approved by the Engineer.

Road Preparation Checklist

- ▶ Weed Removal Complete?
- ▶ Thermo-Plastic striping removed?
- ▶ Pre-Sweep Complete?
- ▶ Utilities Protected?
- ▶ Temporary Markings in Place?



Road Preparation Checklist

Surface Preparation.

- ▶ Hot Mix Cold Lay: Should Cure – 60 days
- ▶ Hot Mix Hot Lay: Should Cure 2 week minimum
- ▶ **BEST PRACTICE: Fog Seal Patches and Leveling Prior to Scrub Seal**
- ▶ Sterilize And Remove Vegetation
- ▶ Remove Thermoplastic striping
 - Sealing over old roughed up striping should be OK
 - **Do NOT create a trough when removing stripe**

Road Preparation Checklist

Food For Thought---Mississippi spec's

- ▶ ***907-410.03.4--Preparation of Surface.***
 - The entire surface to be treated and at least one foot (1') on each side shall be cleaned by sweeping, blowing, or other methods until all dust, mud, clay lumps, and foreign material is removed.

- ▶ ***907-410.03.4.1--Cleaning Pavement.***
 - The roadway surface *shall be cleaned by sweeping no more than 30 minutes prior to application* of the emulsified asphalt and aggregate.

- ▶ ***907-410.03.4.3--Stripe Removal.***
 - Prior to the chip seal operations, the Contractor *shall remove all existing thermoplastic striping, thermoplastics legends, and raised pavement markers within the chip seal limits.*

~~Chip Seal~~ Scrub Seal

433.03 (b) Temperature Limitations.

The scrub seal shall only be placed when the ambient and pavement temperatures are above **50°f** / (10 °C) and rising but below a pavement surface temperature of 140°f (60 °C). The emulsion shall not be placed if there are freezing conditions forecast for 72 hours after placement.

Weather Issues

Emulsion should only be applied when the ambient and pavement temperatures are above ~~70° F.~~ are above **50°f** / (10 °C) and rising



Help Yourself! It's not the fault of the process!

Don't place when rain is in the forecast!



Weather Issues

Effects of
rainstorm
before
emulsion has
cured



Road Preparation Checklist

Surface Preparation.

- ▶ Hot Mix Cold Lay: Should Cure – 60 days
- ▶ Hot Mix Hot Lay: Should Cure 2 week minimum
- ▶ **BEST PRACTICE: Fog Seal Patches and Leveling Prior to Scrub Seal**
- ▶ **Do not apply material at least 2 hours before dusk.**
- ▶ Sterilize And Remove Vegetation
- ▶ Remove Thermoplastic striping
 - Sealing over old roughed up striping should be OK
 - Do NOT create a trough when removing stripe

Road Preparation Checklist

- ▶ Air and Ambient Temperature above 55F*. Above 40F overnight
- ▶ Dry pavement, no rain forecast for 24 hours.
- ▶ Emulsion heated to manufacturers requirements (145 – 185F)
- ▶ Aggregate damp but not wet
- ▶ Tar Paper set at beginning and end of emulsion shot.
- ▶ Chip Spreader width set to leave a narrow strip of uncoated emulsion.



Materials

Materials

Aggregates

Emulsion

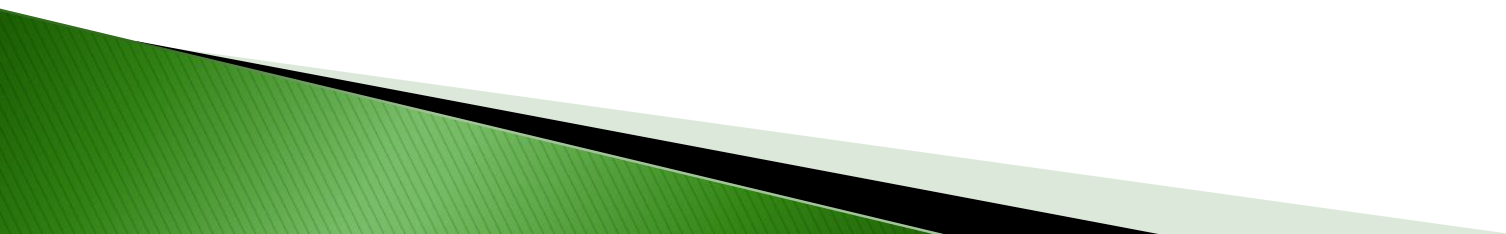

Materials Emulsion

A *Chip Seal* usually uses a polymer-modified asphalt emulsion CRS-2P, without the rejuvenator;

▶ CRS-2P

- **C** = Cationic or Positive Charge
- **RS** = Rapid Set
- **2** = Higher Viscosity
- **P** = Polymer Modified.

Materials

Emulsion

A **Scrub Seal** uses a polymer–modified asphalt emulsion with a rejuvenator, **CMS–1 PC**.

- C = Cationic or Positive Charge
- MS = Medium Set
- 1 = Lower Viscosity
- P = Polymer Modified
- **C = *Rejuvenator***

Materials

Emulsion

A **Scrub Seal** emulsion placement rate for the emulsion shall be from 0.25 to 0.35 gallons per square yard. The Engineer will require that the placement rate be **adjusted up or down as necessary to fill the cracks in the roadway while achieving approximately 60–70% aggregate embedment after rolling.**

Materials



Materials

Aggregates

Emulsion

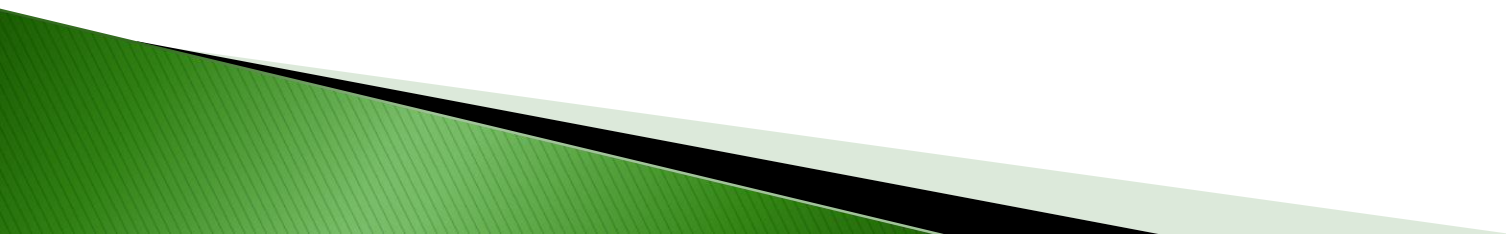

Materials Aggregates



Materials

Aggregates

Best Aggregate Performance when:

- ▶ Single sized
- ▶ Minimum fines
- ▶ Clean
- ▶ Free of clay
- ▶ Cubical
- ▶ Crushed faces
- ▶ Abrasion < 30%
- ▶ Binder compatible
- ▶ Damp for emulsions
- ▶ Dry for hot binders

Materials

Dense Graded



Single Size

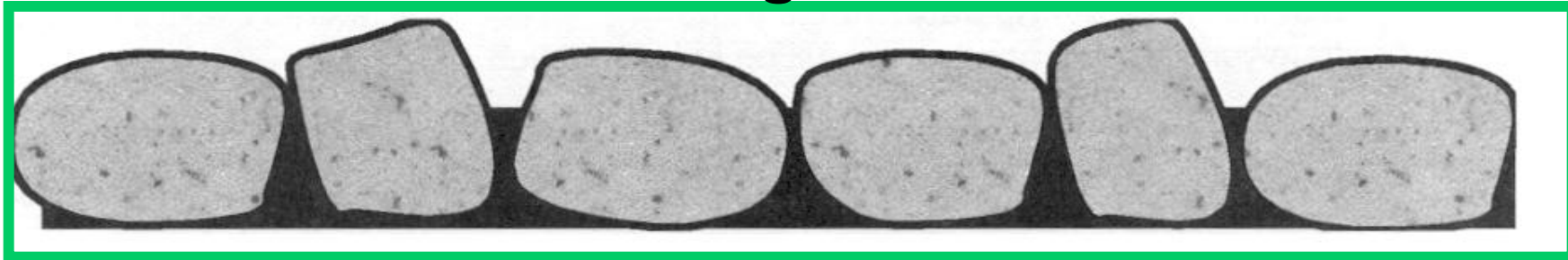

Materials

Embedment

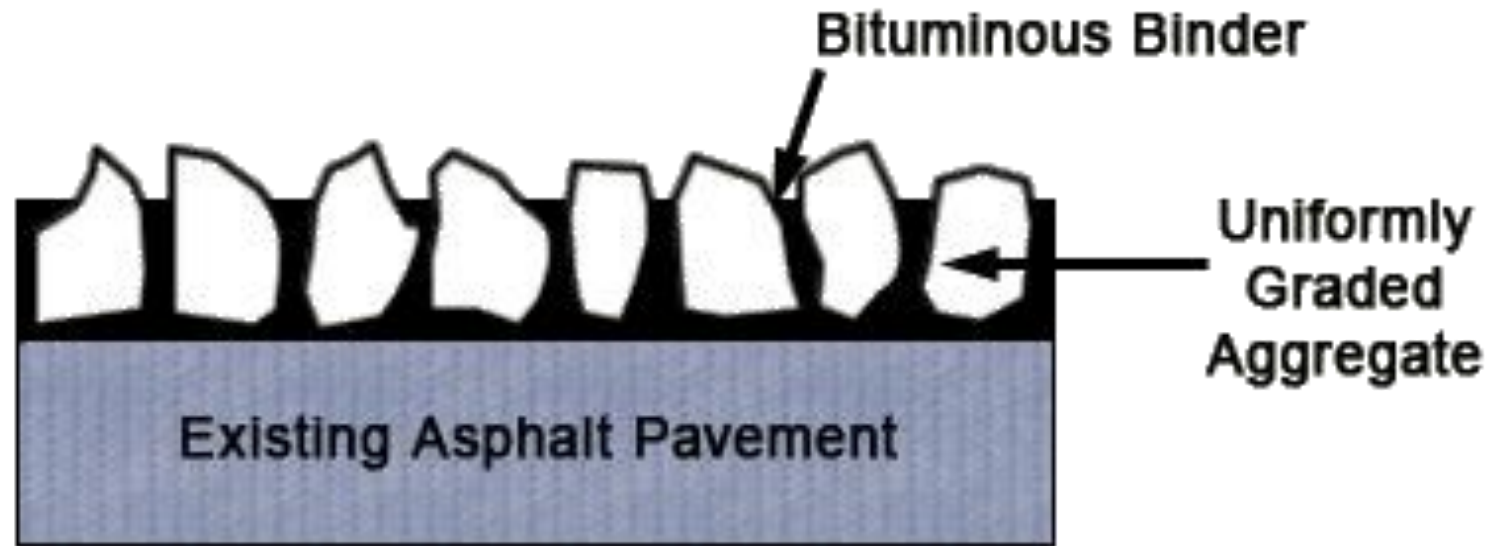

Single Chip Seal

Materials

Aggregates

Scrub Seal 433.02 (b) Aggregate.

The aggregate shall be an ALDOT **Size No. 89 or No. 89** Modified in accordance with the material requirements for bituminous surface treatments given in Section 801 and the modified No. 89 gradation below:

- ▶ Sieve % Passing
- ▶ ½" 100
- ▶ ¾" 90–100
- ▶ #4 20–55
- ▶ #8 0–15
- ▶ #16 0–10
- ▶ #50 0–5

Materials

Aggregates

Scrub Seal 433.03 Construction Requirements.

(a) Placement Rates.

The placement rate for the aggregate shall be from 18 to 25 pounds per square yard. The Engineer will require that the placement rate be adjusted so that no bleed through occurs during rolling.

Materials

Aggregates

Scrub Seal 433.03 Construction Requirements.
(f) Material Application.

- ▶ The aggregate **shall be dry during spreading**. The aggregate shall be evenly spread over the scrubbed emulsion.

Materials

Aggregates

Scrub Seal 433.03 Construction Requirements. (f) Material Application.

- ▶ For inner layer applications the scrub seal shall be sufficiently cured prior to placing a bituminous overlay, micro-surfacing, or other asphalt surface treatments.
- ▶ The Engineer will require a second power sweeping of the scrub seal surface at least 72 hours after completion of the placement of the emulsion and aggregate to determine the status of the scrub seal being cured.
- ▶ For instances where the scrub seal is to be placed beneath hot mix asphalt of 134 lb/sy or less, the curing period shall be raised from 72 hours to at least 7 days.
- ▶ The ability to sweep all loose aggregate from the surface without removing any aggregate adhered to the bituminous emulsion shall determine that the scrub seal is cured.

Good Stockpile Maintenance is Necessary



Chips should be “surface damp”



Too Dusty



Too Wet

Asphalt Emulsion

Asphalt Emulsion



Asphalt Emulsion



- ▶ **CMS-1 PC**
 - Medium Set
 - Polymer modified
 - Rejuvenating agent
- ▶ **140° – 180° temp range**
 - Check with manufacturer.
- ▶ **#7 Aggregate – 0.33 ± 0.03 gal/yd²**
- ▶ **#89 Aggregate – 0.30 ± 0.03 gal/yd²**

Asphalt Emulsion

Emulsion Application Rates

- ▶ Target rates for Scrub Seals
 - #7 – 0.33 ± 0.03 gal/yd²
 - #89 – 0.30 ± 0.03 gal/yd²
 - Application rate is dependent on pavement condition and aggregate gradation. **Don't cheat on the application rate.**

Asphalt Emulsion

Scrub Seal 433.03 Construction Requirements.

(a) Placement Rates.

The placement rate for the emulsion shall be from ***0.25 to .35 gallons per square yard.*** The Engineer will require that the placement rate be adjusted up or down as **necessary to fill the cracks** in the roadway while achieving approximately **60–70% aggregate embedment** after rolling.

Asphalt Emulsion

Shot Rate Adjustments

Pavement Condition	Factor	Adjustment
Flushed asphalt surface	0.70	-0.03 gal/yd ²
Smooth, non-porous surface	0.90	0.00 gal/yd ²
Slightly porous, oxidized surface	0.94	+0.02 gal/yd ²
Slightly pocked, porous surface	0.90	+0.04 gal/yd ²
Badly pocked, porous, oxidized surface	0.90	+0.06 gal/yd ²

Equipment

Equipment

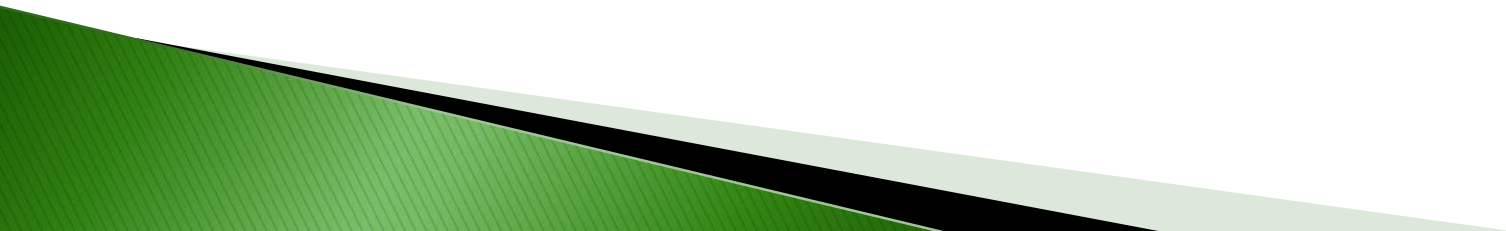

Sequence of a Scrub/Chip Seal Project

Equipment Placement

Road Preparation

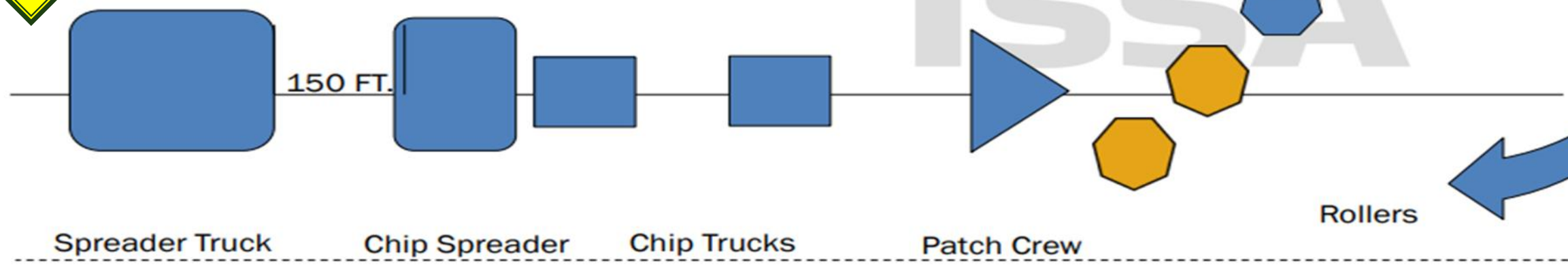
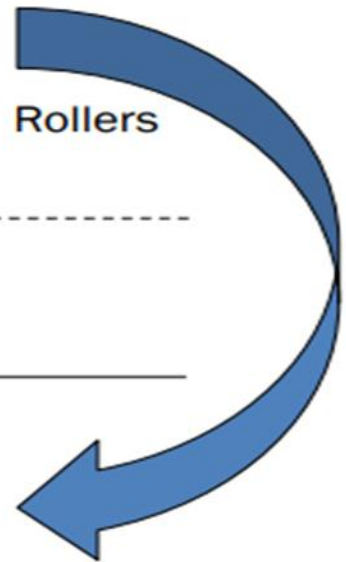

Equipment

Equipment Placement

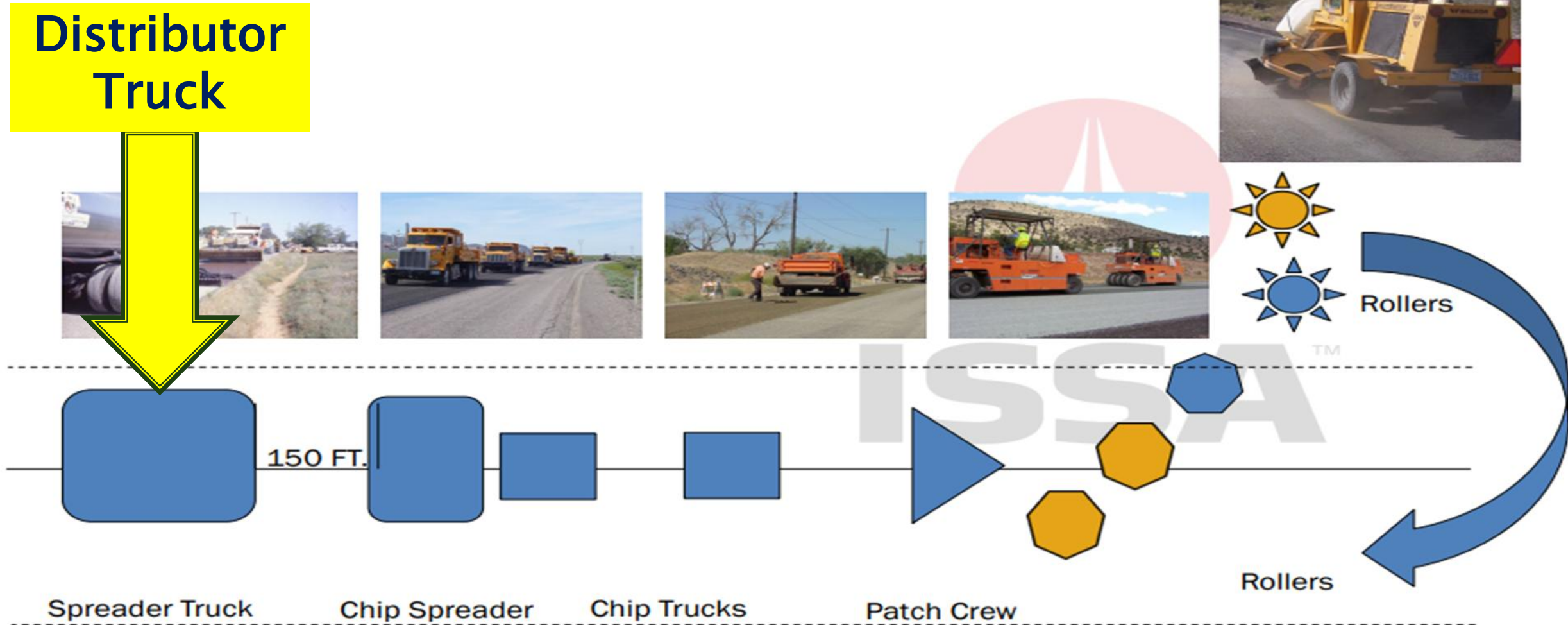

Equipment

Asphalt Distributor & Checklist

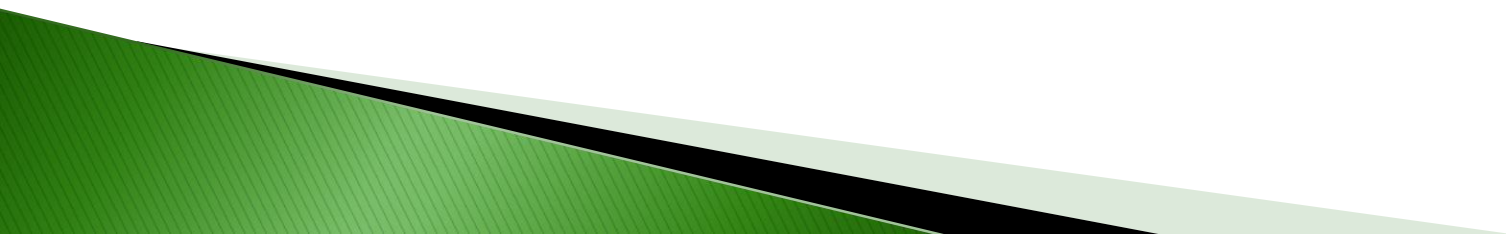

Equipment

Asphalt Distributor & Checklist



Equipment

Asphalt Distributor & Checklist

Chip Seal

401.03 (a) 2. Pressure Distributor. A pressure distributor shall be required and shall be so designed and operated that it will distribute the contents in a uniform spray for the full width of the treatment area without atomization, at the ***rate and within the limits specified***... Suitable ***measuring equipment for accurately measuring the volume of the contents shall be provided***. The distributor shall be equipped with a spray bar of adjustable height, hand hose, and nozzle.

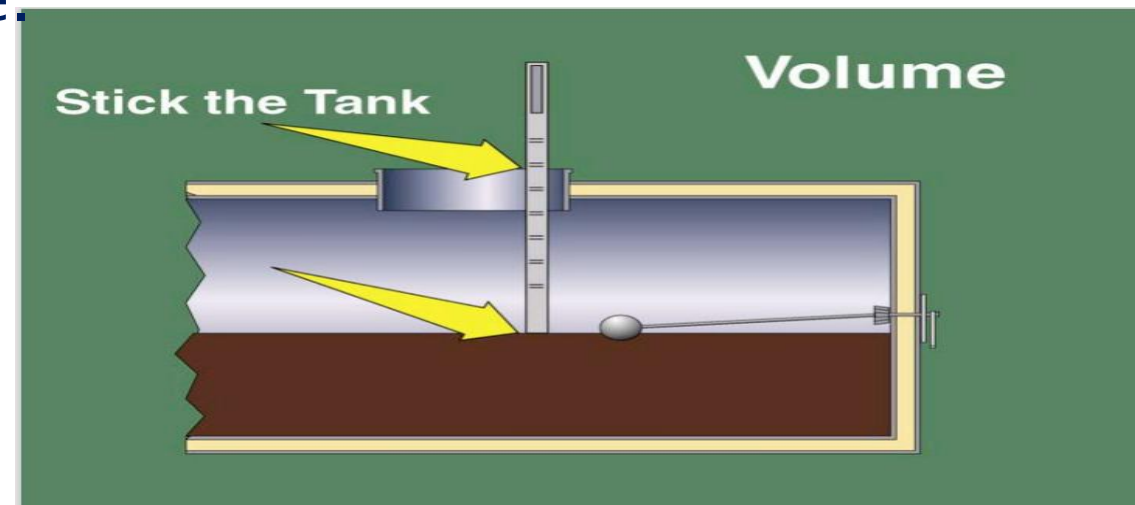

Equipment

Asphalt Distributor & Checklist

Scrub Seal

433.03 (e) Equipment.

1. Asphalt Distributor. An asphalt distributor shall be furnished for the application of the asphalt emulsion. The distributor shall have a full circulating spray bar that is adjustable to at least 16 feet wide in two feet increments and is capable of heating and circulating the emulsion simultaneously.

It shall have ***computerized rate control*** for adjusting and controlling the application from the cab. The rate shall be adjustable by .01 gallons per square yard increments. ***The distributor shall also be equipped with a volume measuring device and a thermometer for measuring the emulsion temperature in the tank.***

Equipment

Asphalt Distributor & Checklist

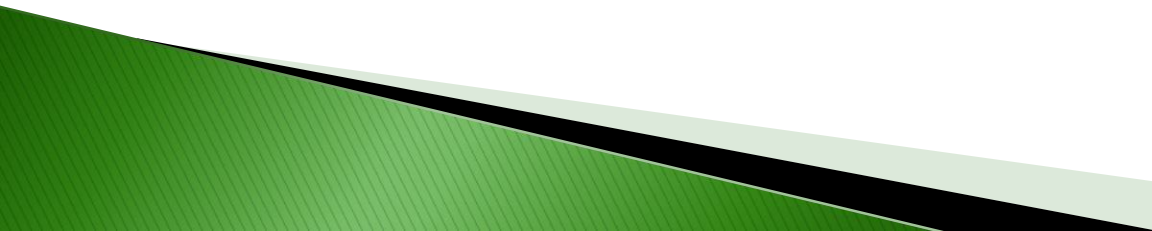
- ▶ Computerized
 - ▶ Able to Circulate between tank and Bar
 - ▶ Working radar
 - ▶ Working Thermometer for measuring temperatures in the tank.
 - ▶ Heating when required
 - ▶ Gallon Gauge / Calibrated dip stick
 - ▶ Correct tips (nozzles) for application
 - ▶ Strainers are cleaned. No clogs
- 

Equipment

Asphalt Distributor & Checklist

Why Should You Check Your Distributor's Calibration?

- ▶ To make sure the computer rate matches what's going on the ground
- ▶ To avoid bleeding or flooding of material
- ▶ To make sure there is enough material to retain the chip, or assure a good bond for paving surface
- ▶ To avoid increased cost of material, due to over application

Distributor Checklist



1
3353788



2
3351008



3
3351009



4
3352368



5
3351015



6
3352204



7
3352205



8
3352210



9
3351014



10
3351010

Ref.	Part No.	Description	Application Per Square Yard	Application (Metric) Liters Per Square Meter	Flow Gallons Per Minute Per Foot
1	3353788	V Slot Tack Nozzle	.05 - .20	.19 - .75	3.0 to 4.5
2	3351008	S36-4 V Slot	.10 - .35	.38 - 1.30	4.0 to 7.5
3	3351009	S36-5 V Slot	.18 - .45	.57 - 1.50	7.0 to 10.0
4	3352368	Multi-Material V Slot	.15 - .40	.57 - 1.50	6.0 to 9.0
5	3351015	3/32" Coin Slot	.15 - .40	.57 - 1.50	6.0 to 9.0
6	3352204	Multi-Material V Slot	.35 - .95	1.30 - 3.60	12.0 to 21.0
7	3352205	Multi-Material V Slot	.20 - .55	.75 - 2.08	7.5 to 12.0
8	3352210	End Nozzle (3352205)	.20 - .55	.75 - 2.08	7.5 to 12.0
9	3351014	3/16" Coin Slot	.35 - .95	1.30 - 3.60	12.0 to 21.0
10	3351010	1/4" Coin Slot	.40 - 1.10	1.50 - 4.16	15.0 to 24.0

#6 Recommended for Chip Seals

Match Nozzles to Application

Distributor Checklist

CORRECT

Sprayer Nozzles at Same Angle

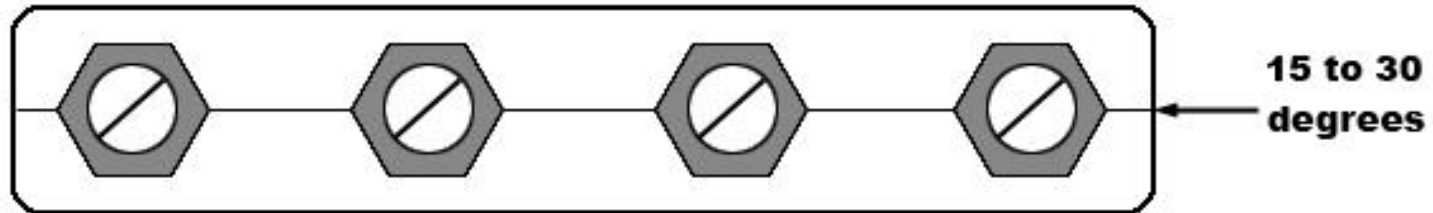

INCORRECT

Sprayer Nozzles at Different Angles

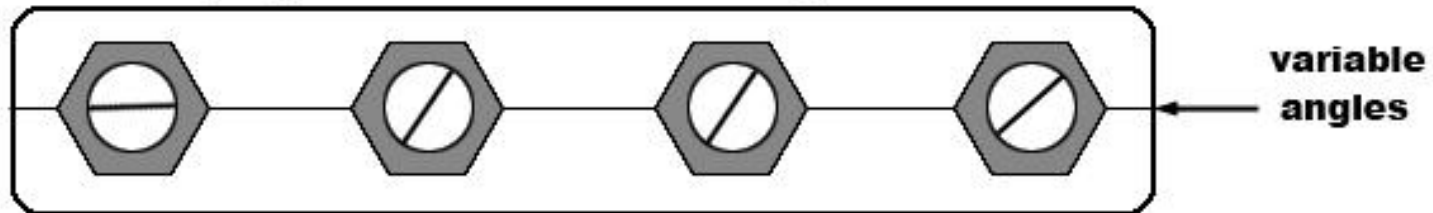

Spray Bar Nozzle Alignment

Distributor Checklist

Same Angle

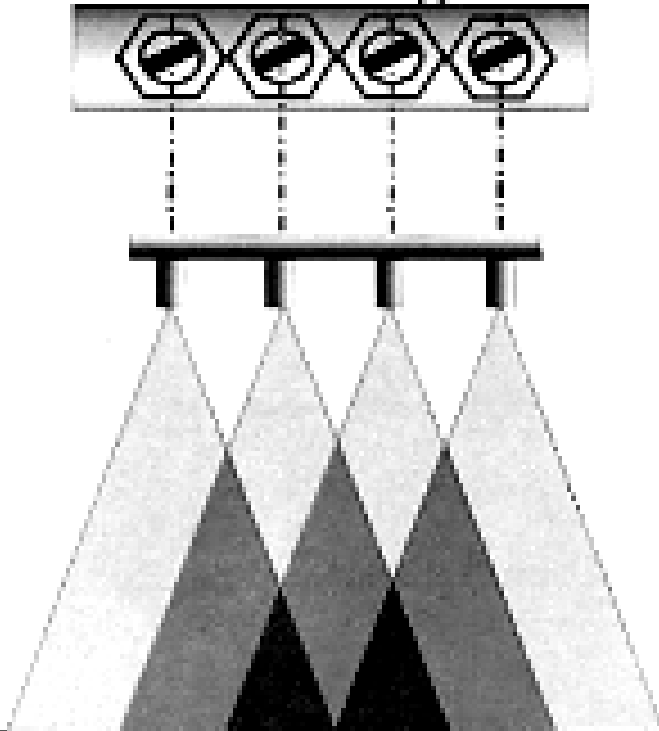

Fans are the same width

Different Angles

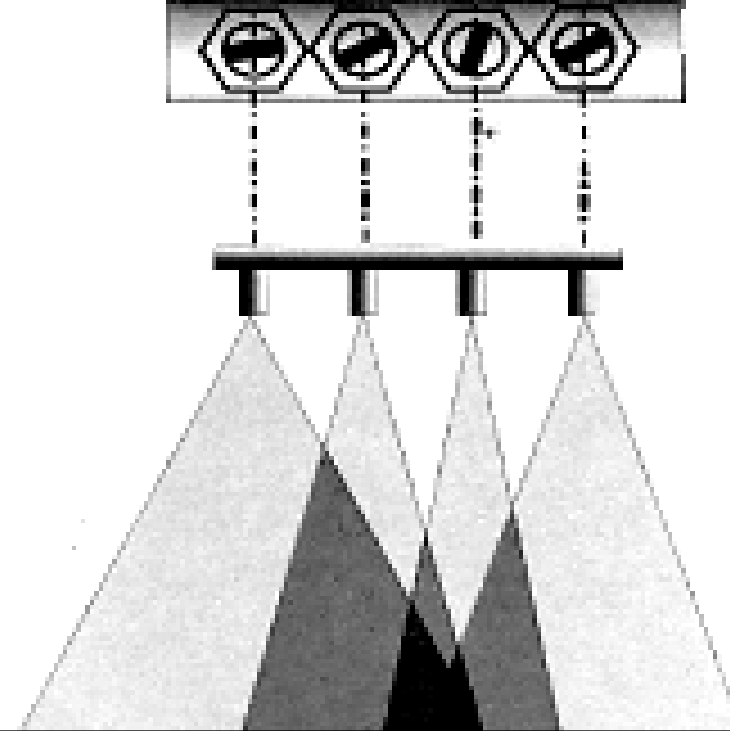

Fans are different widths

Spray Bar Nozzle Alignment

Distributor Checklist

Spray Bar Nozzle Alignment

Nozzle Slot 30° from Spray Bar

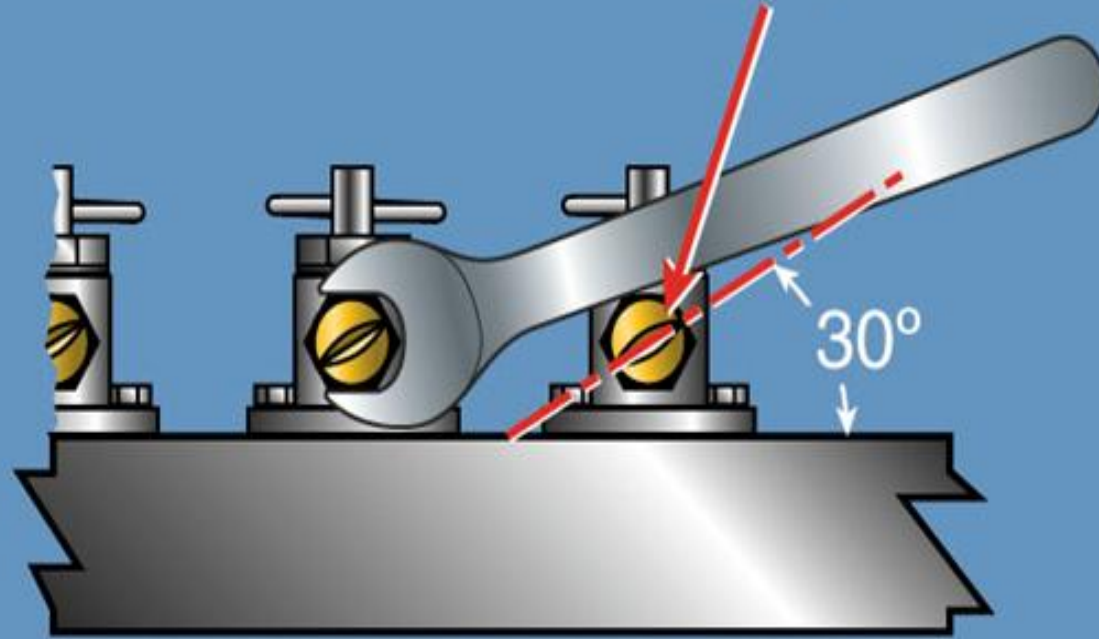

Distributor Checklist

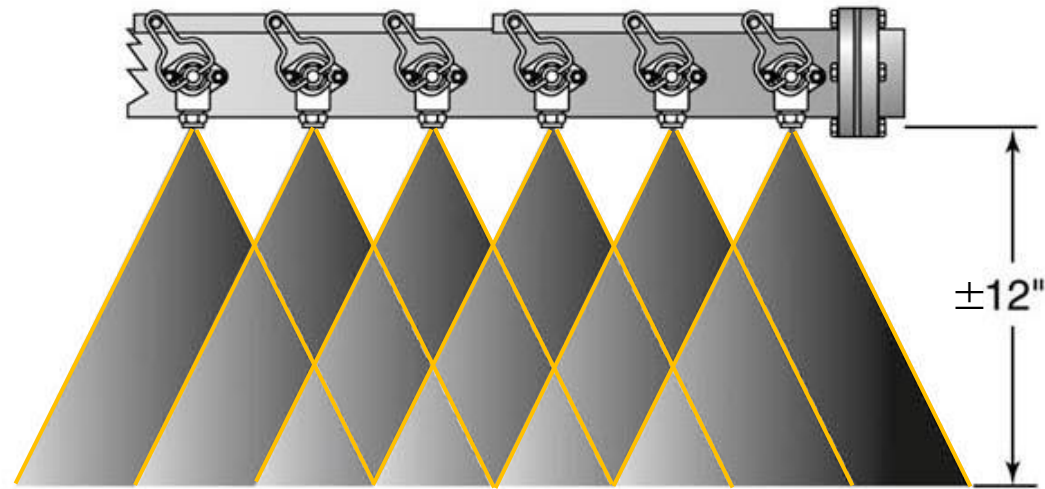

Triple-Lap Coverage

With nozzles on 4" centers, material sprayed from each nozzle overlaps two other sprays.

Distributor Checklist

Adjusting Spray Bar Height

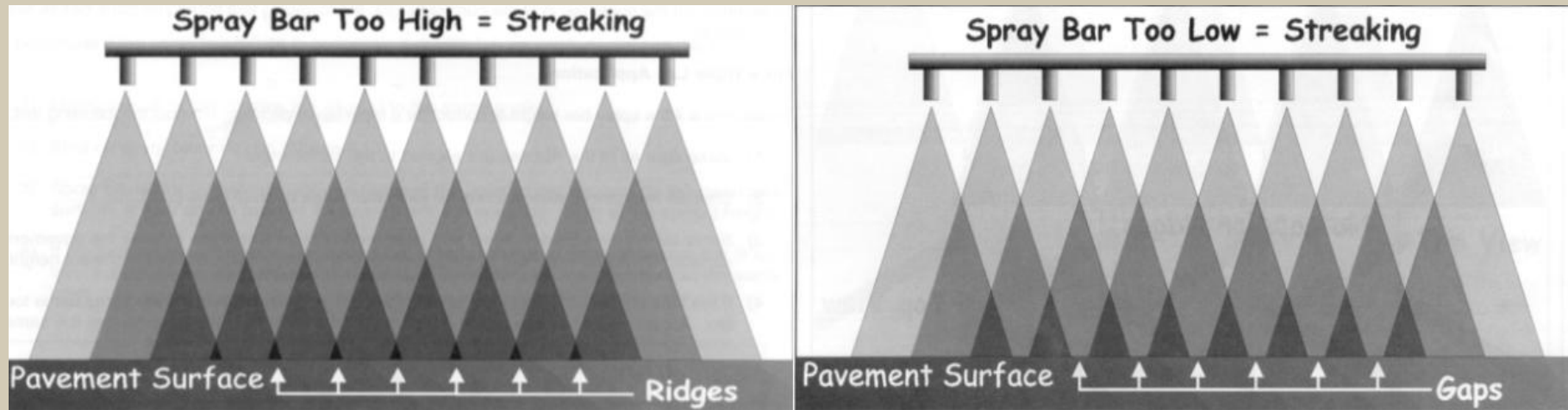

Too High = Ridges

Too Low = Gaps

Distributor Checklist

Improper Spray Bar Height



Distributor Shot Rates

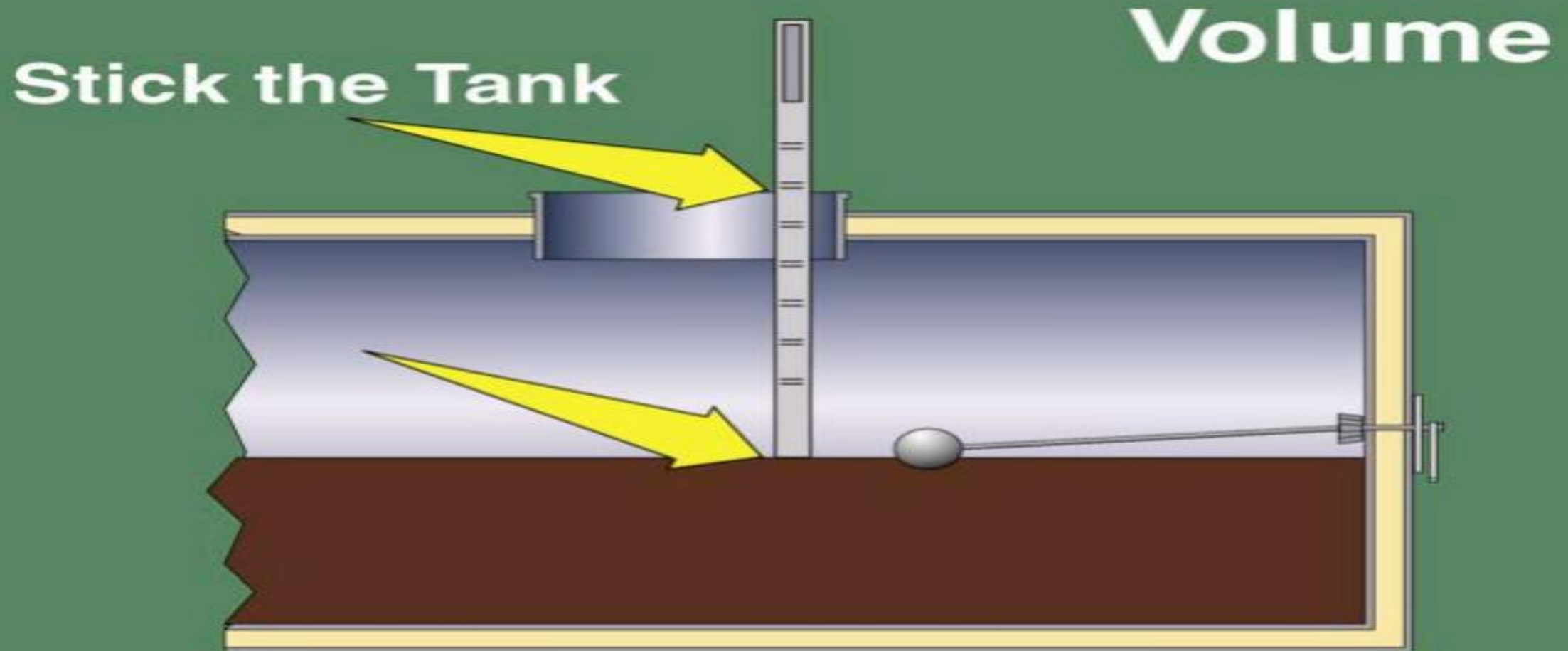

Before checking your volume by sticking the tank, make sure Distributor is level



Distributor Shot Rates

Weight

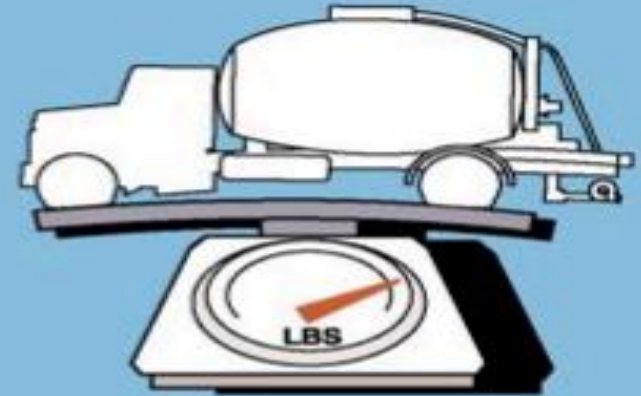

(g/y)

(Feet)

Longitudinal Rate Test

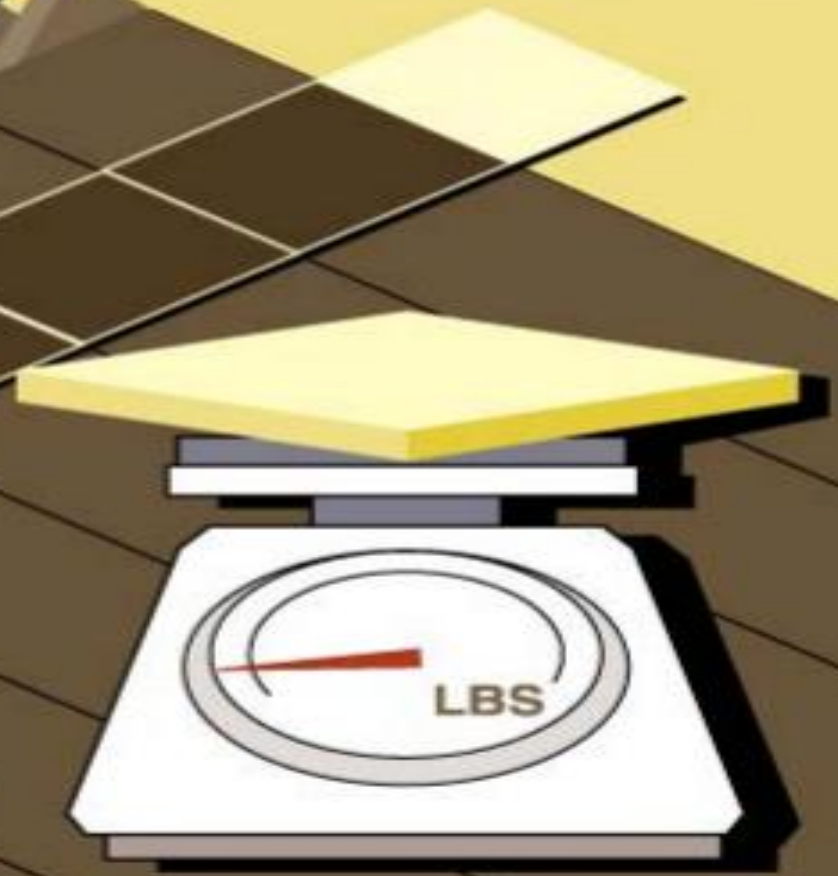

— **Weight**

Equipment

Equipment Placement

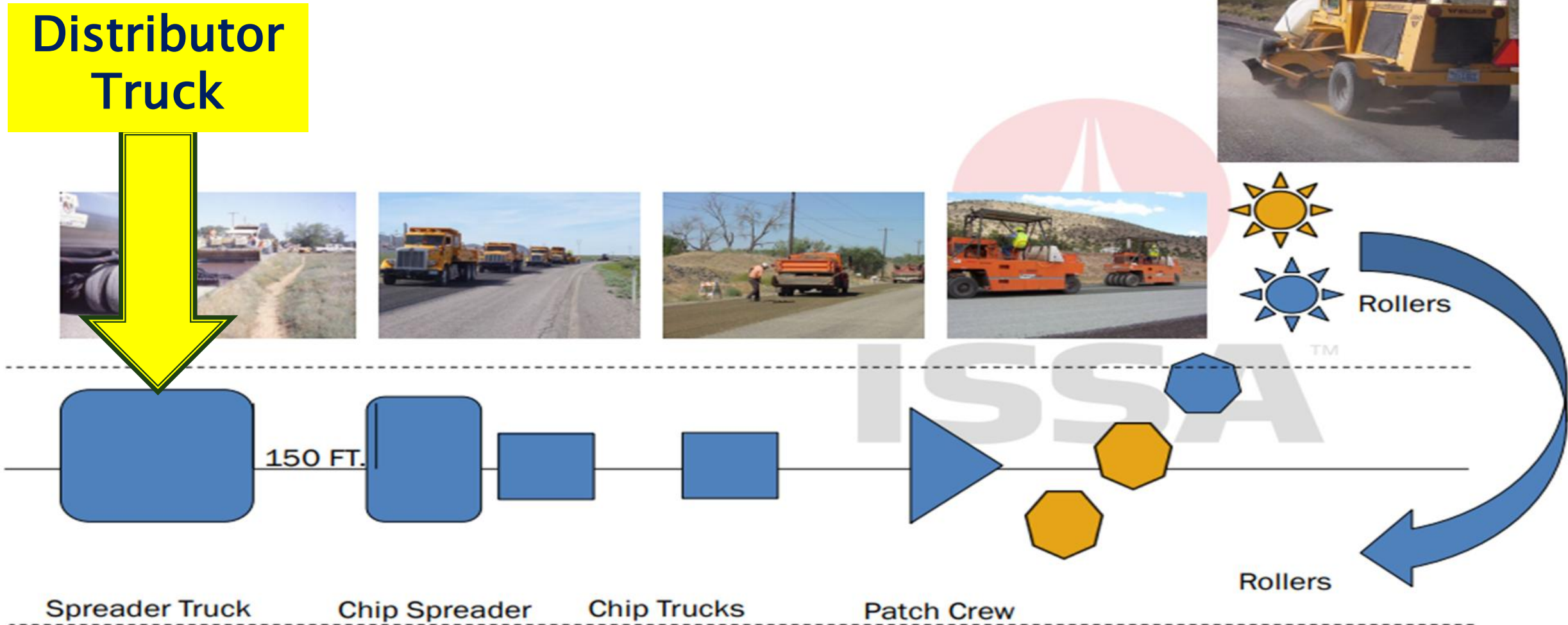

Rollers

Rollers

Spreader Truck

Chip Spreader

Chip Trucks

Patch Crew

ISSA

Equipment

Equipment Placement

Scrub
Broom



Rollers

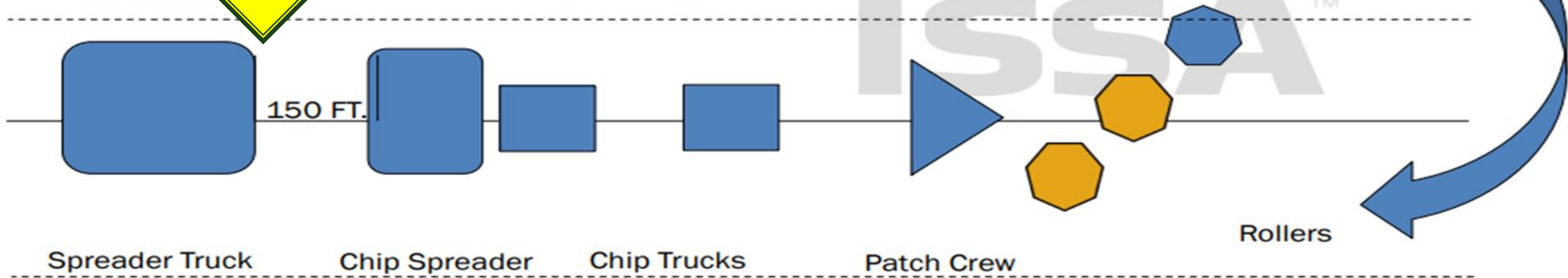

Equipment

Equipment Placement

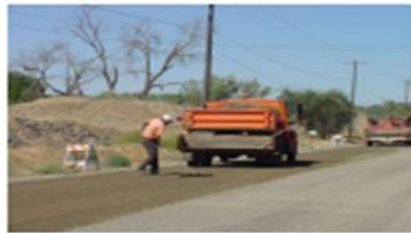

Rollers

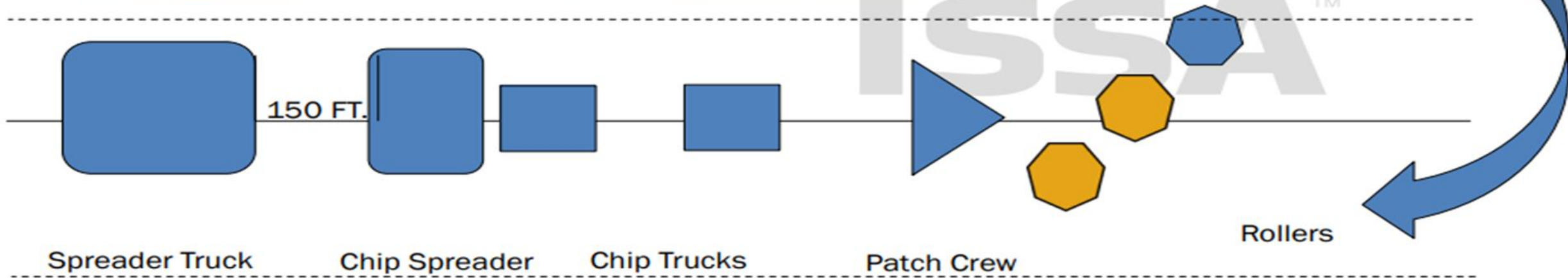

Equipment

Scrub Broom

Equipment

Scrub Broom

433.03 Construction Requirements (e) Equipment

2. Emulsion Broom.

- ▶ The emulsion broom sled frame shall be constructed of metal.
- ▶ The emulsion broom sled shall be attached to and pulled by the distributor truck.
- ▶ The emulsion broom sled must be equipped with a means of raising and lowering the emulsion broom sled at desired points. It shall be towable in the elevated position.
- ▶ The broom sled assembly shall be adjustable so that it does not squeegee the emulsion off the roadway surface or outside the framework of the broom sled.
- ▶ The main body of the emulsion broom sled shall have a minimum frame size of 6.5 feet wide and 10 feet long. The maximum transverse rigid frame width at any point shall not exceed 6.75 feet.
- ▶ The nearest and furthest members, paralleling the back of the spreader truck, and diagonal members shall be equipped with street brooms. The leading member and the trailing member shall have brooms heads angled at 10 to 15 degrees off the centerline of the supporting member.
- ▶ The diagonal members shall have broom heads attached in line with the centerline of the supporting member. Each individual street broom attached to the emulsion broom sled assembly shall be 3.5 inches wide x 6.5 inches high x 16 inches long and have stiff nylon bristles. Bristle height is to be maintained at a minimum of five inches (5").
- ▶ The emulsion broom shall be equipped with hinged wing assemblies attached to the main body not to exceed 4.5 feet per side, with diagonals and equipped with street brooms. The purpose of the maximum rigid frame width and the hinged wing extensions is not only for maximum width of 16 feet but to maintain the scrubbing process evenly as contours and cross-sections change across the existing road surface.

Equipment

Scrub Broom

433.03 Construction Requirements (e) Equipment

2. Emulsion Broom.

- ▶ The emulsion broom sled frame shall be constructed of metal.
- ▶ The emulsion broom sled shall be attached to and pulled by the distributor truck.
- ▶ The emulsion broom sled must be equipped with a means of raising and lowering the emulsion broom sled at desired points.
- ▶ It shall be towable in the elevated position.
- ▶ The broom sled assembly shall be adjustable so that it does not squeegee the emulsion off the roadway surface or outside the framework of the broom sled.

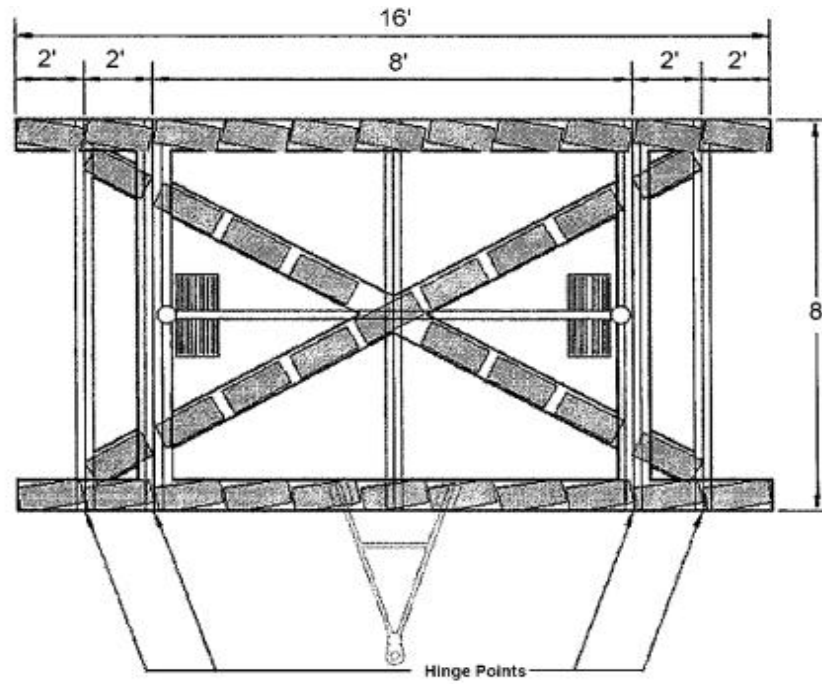

Street Broom w/ Nylon Bristles

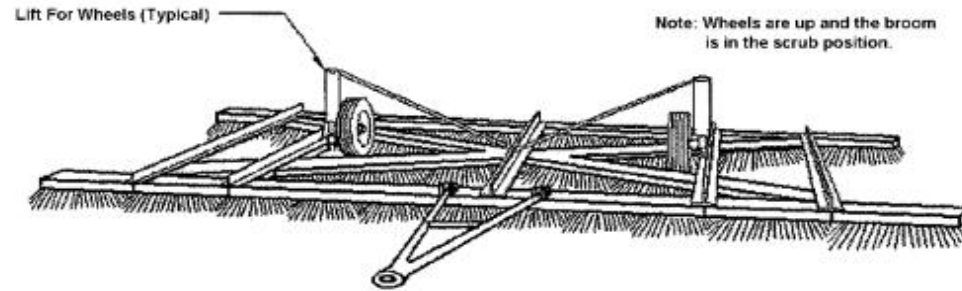

Scrub Broom

Scrub Broom w/Emulsion Wave

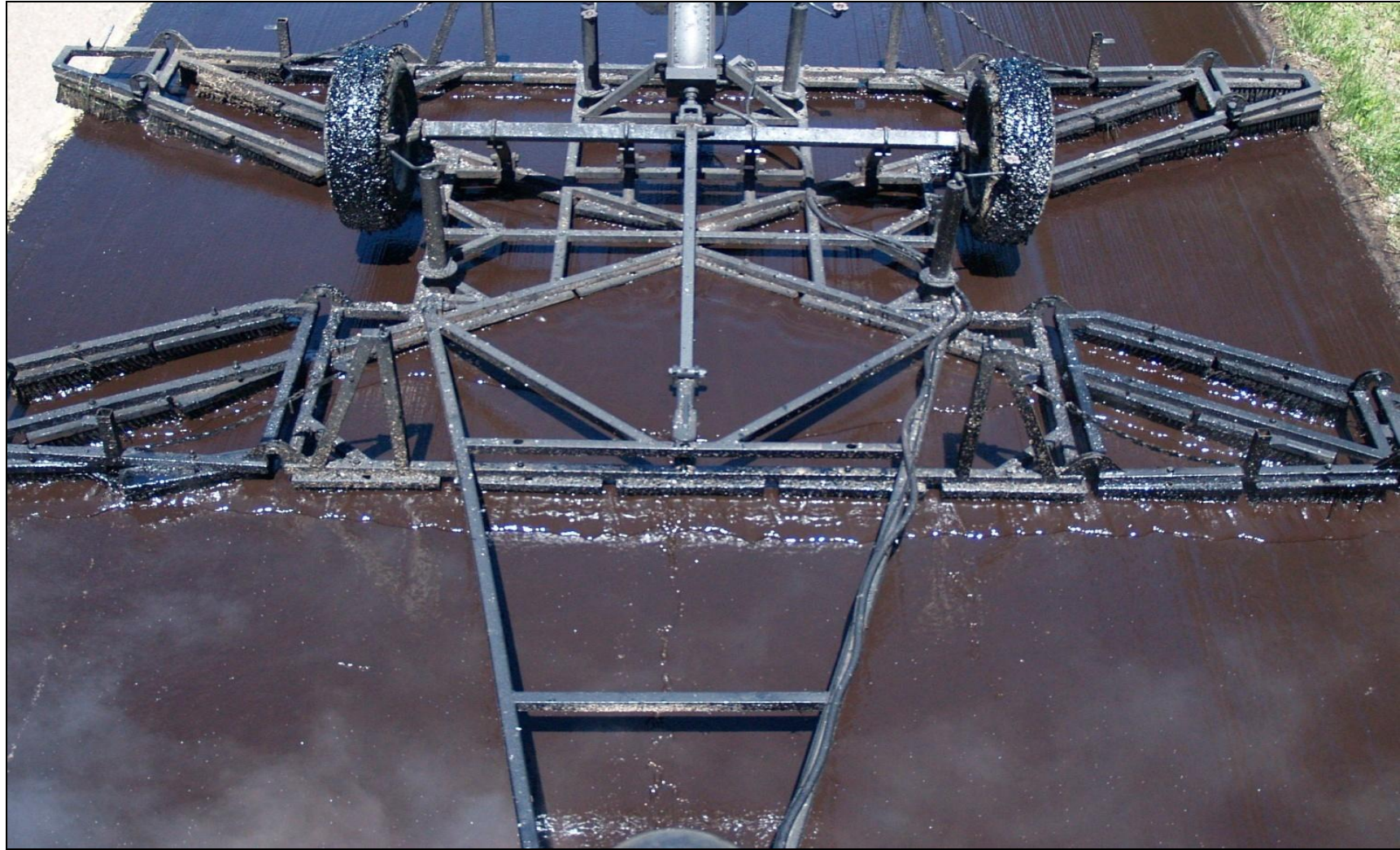

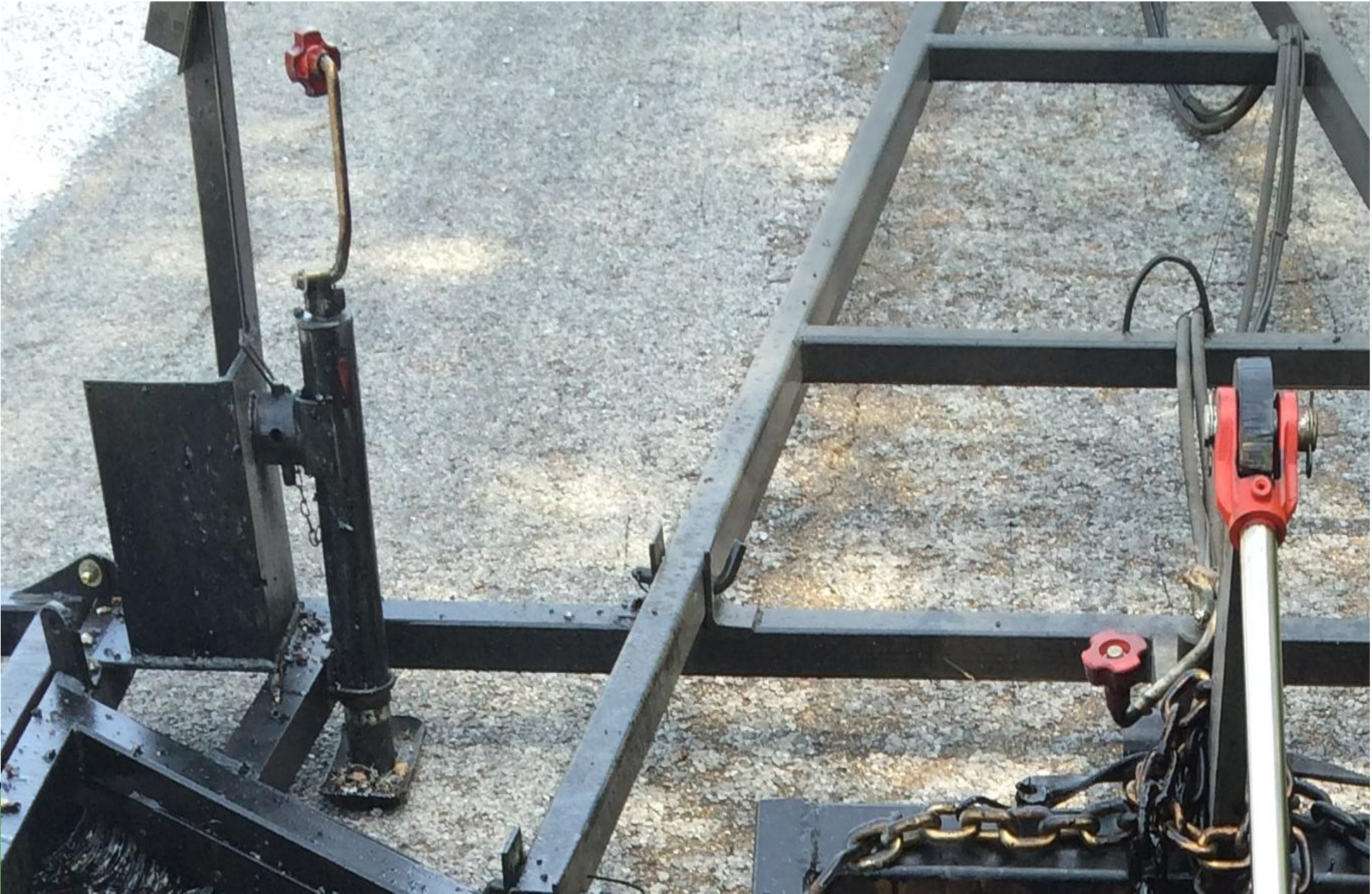

Broom Heads Ride on the Surface

**Brooms should
be aligned**

**Bristles should
be clean**







Brushes barely touching the pavement.



Too MUCH
weight on
broom heads.

Keep Broom Level with Road Surface

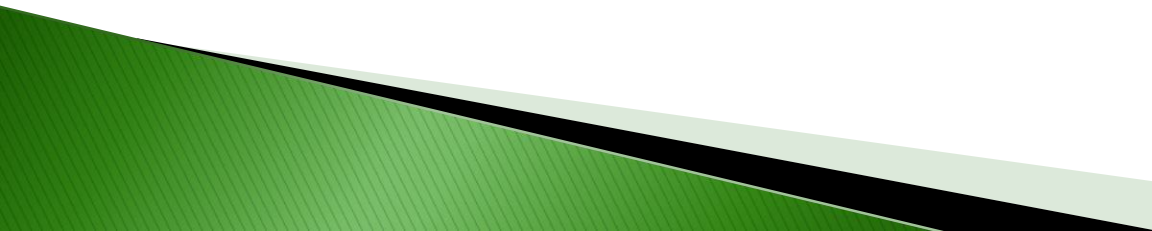

Things We Have Learned Before Job Ever Starts

- **Do a training for the Inspectors and contractors!**
 - **Things to check for on the broom**
 - **Make sure air is working to the broom**
 - **Make sure the broom heads are clean!**
 - **Broom heads are touching surface**
 - **If Broom has skis that they are functioning & on the surface**
- 

Things We Have Learned Before Job Ever Starts

- If broom has metal wheels instead of skis, make sure they are functioning.
 - Do a dry run with the broom to get acquainted.
 - Cleaning off your broom heads at the end of the day will significantly extend the life of them.
 - Do a test section
- 

Broom

- ▶ What should you do when you are stopping?
- ▶ You need to refill the distributor. Now what?
- ▶ What should you do when you can't use the broom?



Broom

- ▶ The application of the polymer modified asphaltic rejuvenating emulsion and scrub broom operation shall cease 40 feet prior to the end of the application.
- ▶ The remaining polymer modified asphaltic rejuvenating emulsion shall be drug out by the scrub broom. Remaining emulsified material required to complete the pass to be applied by distributor truck.



MAY 7 2004



MAY 7 2004





Equipment

Equipment Placement

Scrub
Broom



Rollers

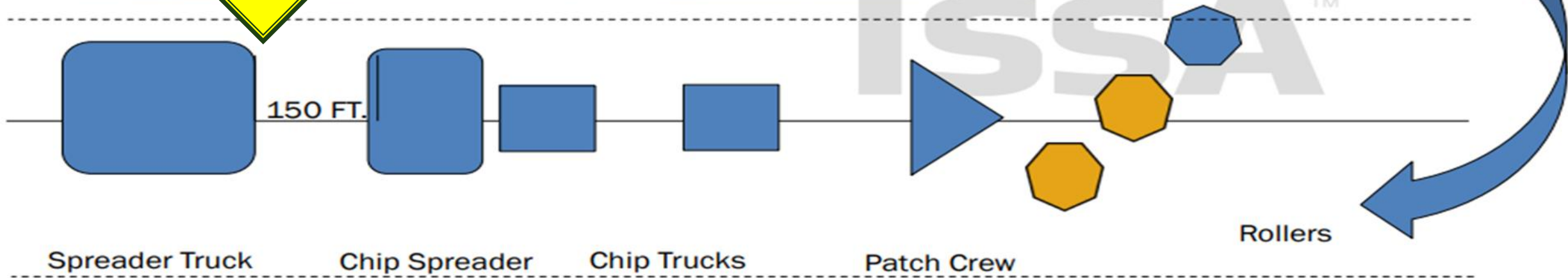

Equipment

Equipment Placement

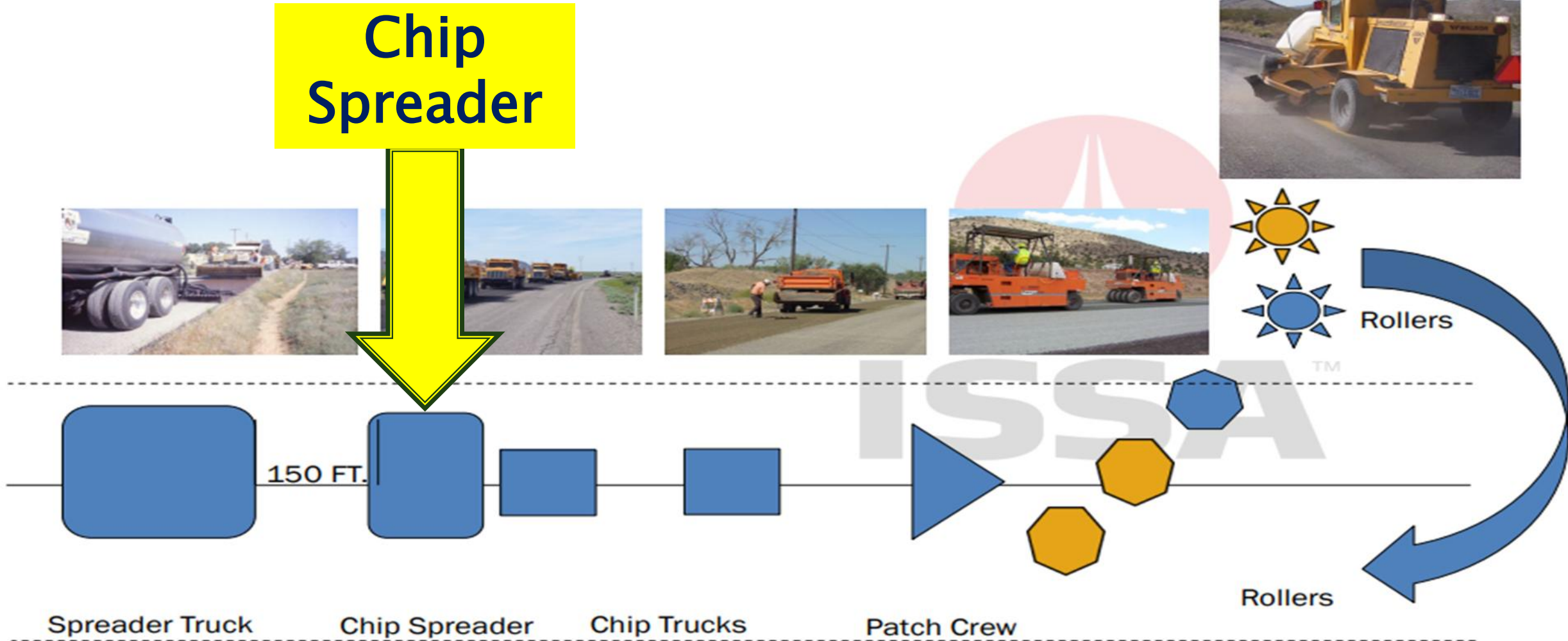

Equipment

Chip Spreader Checklist





Benh Cat 95022
CRC Computerized Rate Control

AVS INTERNATIONAL
800-745-1111

SAFETY
KEEP OFF OF MOWER
WHEN ENGINE
IS RUNNING
AVS
DO NOT REAR
SEAT BELT
OR OTHER
RESTRAINTS
OR DEVICES

Chip Spreader Checklist

- ▶ Uniform aggregate application is a must
- ▶ Calibrated to ensure consistent discharge across width
- ▶ Hopper clean and clear of debris and clogs.
- ▶ Spread Hopper Gates are set correctly.
- ▶ Well Maintained, no hydraulic leaks.
- ▶ Correct Tire Pressure
 - Unit will bounce if pressure is too high.

Chip Spreader Checklist

- ▶ Uniform aggregate application is a must
- ▶ ***Calibrated to ensure consistent discharge across width***
- ▶ Hopper clean and clear of debris and clogs.
- ▶ Spread Hopper Gates are set correctly.
- ▶ Well Maintained, no hydraulic leaks.
- ▶ Correct Tire Pressure
 - Unit will bounce if pressure is too high.





Longitudinal Rate Test

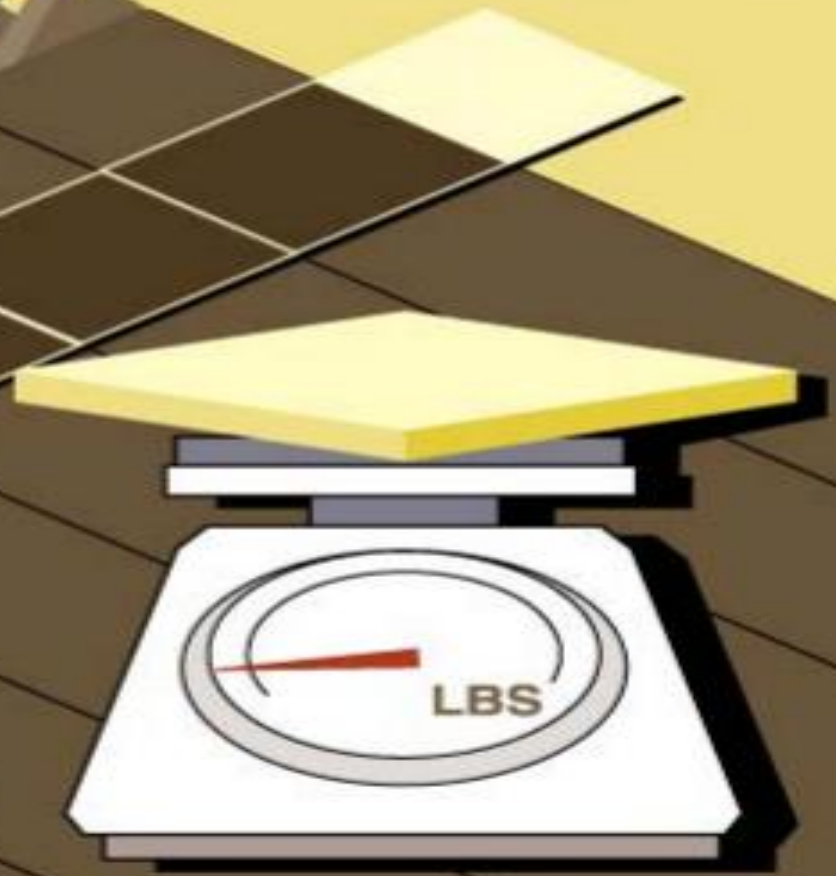

— **Weight**

Alabama Equipment Calibration

Alabama Bituminous Surface Treatments 401

401.03 (a) 3--*Aggregate Spreader.*

A self-propelled aggregate spreader with mechanically actuated spreading attachments and adjustable widths of satisfactory design and performance will be required;

However, when the area to be processed is of such size or shape that to require the use of a mechanical spreader would be impractical, the Engineer may permit the aggregate to be spread manually.

Alabama Equipment Calibration

Alabama Scrub Seal Section 433

433.03(e)3– *Aggregate Spreader.*

A self-propelled spreader with computerized rate control shall be used to spread the aggregate. The spreader shall have front discharge and shall be capable of evenly distributing the aggregate at the required placement rates.

Alabama Equipment Calibration

Alabama Scrub Seal Section 433 &

Alabama Bituminous Surface Treatments 401

***NO Mention of required
Calibration in Alabama Spec's
for Distributor or Spreader?***

Alabama Equipment Calibration

Food For Thought---Mississippi spec's

907-410.03.3.8--Equipment Calibration.

- The Contractor shall provide proof of calibration of the asphalt distributor and the aggregate spreader.
- Calibration shall be conducted no earlier than five days prior to chip seal operations.
- The Contractor shall submit the results of the calibration procedure to the Engineer.

Alabama Equipment Calibration

Food For Thought—Mississippi spec's

907-410.03.3.6—*Application of Cover Coat Mat'l.*

- *During the first day of production and at least once a week* thereafter, the application rate of the seal aggregate shall be verified by the Department...
- If at any point during production, excessive seal aggregate is noted, the seal aggregate application rate should be verified, and the spread rate adjusted.

Chip Spreader Checklist

- ▶ Uniform aggregate application is a must
- ▶ Calibrated to ensure consistent discharge across width
- ▶ Hopper clean and clear of debris and clogs.
- ▶ Spread Hopper Gates are set correctly.
- ▶ Well Maintained, no hydraulic leaks.
- ▶ Correct Tire Pressure
 - Unit will bounce if pressure is too high.

Chip Spreader Checklist



- ▶ Chip Spreader stays within 150 ft. of Asphalt Distributor.
- ▶ Adjust speed so that Chip Spreader doesn't bounce.
- ▶ Stop after first 1,000 ft. Check for:
 - Emulsion Application Rate
 - Too Little Emulsion is much worse than Too Much!
 - Aggregate Application Rate
 - Salt and Pepper
 - Embedment
 - Quality of Mat
 - No streaks, ridges, pickups

Chip Spreader Checklist

Emulsion/Agg Spreading

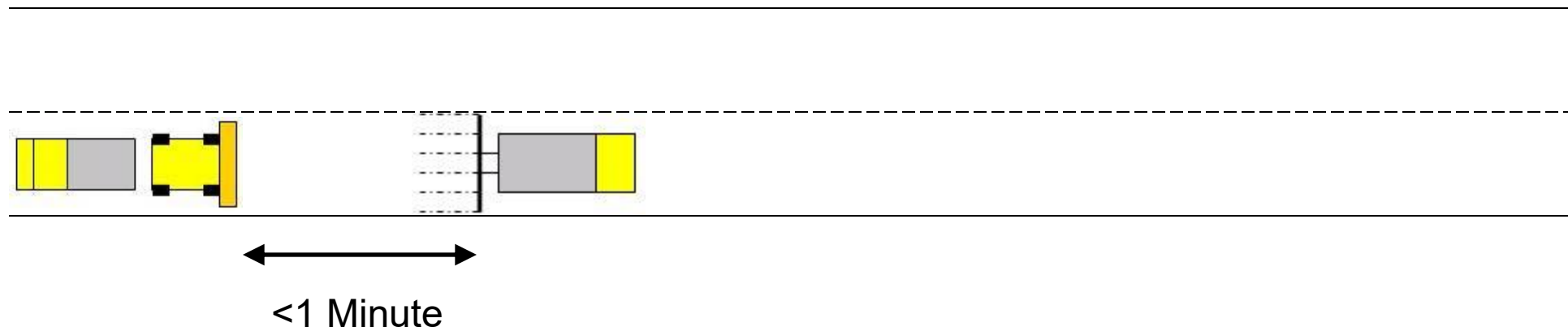

This way...

Distributor and Agg Spreader Virtually Joined Together

Chip Spreader Checklist

Emulsion/Agg Spreading



NOT this way...

Causes too many joints, and may cause uneven chip retention

Chip Spreader Checklist

Alabama Bituminous Surface Treatments 401

401.03 (e) Spreading and Embedding Aggregate.

- ▶ The size and amount of aggregate used shall be in accordance with provisions of Subarticle 401.01(b) for the type treatment required by the plans or proposal.
- ▶ Spreading of aggregate shall follow application of bituminous material as closely as practicable using mechanical aggregate spreaders; inaccessible areas shall be covered as directed.
- ▶ Sufficient aggregate to cover each distributor load, in loaded trucks along with an adequate crew of workmen equipped with brooms standing by, shall be at the site before bituminous application begins.
- ▶ Spreading of the aggregate shall begin and continue immediately behind the application of the bituminous material.
- ▶ However, if excessive rolling of the aggregate occurs during spreading, the Engineer may allow the chip spreader to delay slightly in order to hold aggregate rolling to a minimum.
- ▶ Rolling shall begin immediately behind the spreading operation. Sufficient rollers shall be furnished to ensure that the initial pass of the roller is made within five minutes of the spreading of the aggregate.
- ▶ Rolling shall be continuous, providing coverage of the entire area of treatment to ensure thorough embedment of the aggregate.
- ▶ Unless a sufficient number of rollers are in operation to complete the above requirement, the next load of bituminous material shall not be applied until the rolling of the previous application is completed.
- ▶ When the Engineer determines the aggregate has been thoroughly embedded, rolling shall cease and the Contractor shall, without delay, remove all excess aggregate from the treatment area.

Chip Spreader Checklist

Alabama Bituminous Surface Treatments 401

401.03 (e) Spreading and Embedding Aggregate.

- ▶ Spreading of aggregate shall follow application of bituminous material as closely as practicable using mechanical aggregate spreaders; inaccessible areas shall be covered as directed.
- ▶ Sufficient aggregate to cover each distributor load, in loaded trucks along with an adequate crew of workmen equipped with brooms standing by, shall be at the site before bituminous application begins.
- ▶ Spreading of the aggregate shall begin and continue immediately behind the application of the bituminous material.
- ▶ However, if excessive rolling of the aggregate occurs during spreading, the Engineer may allow the chip spreader to delay slightly in order to hold aggregate rolling to a minimum.

Chip Spreader Checklist

Embedment

Average Least Dimension (H)

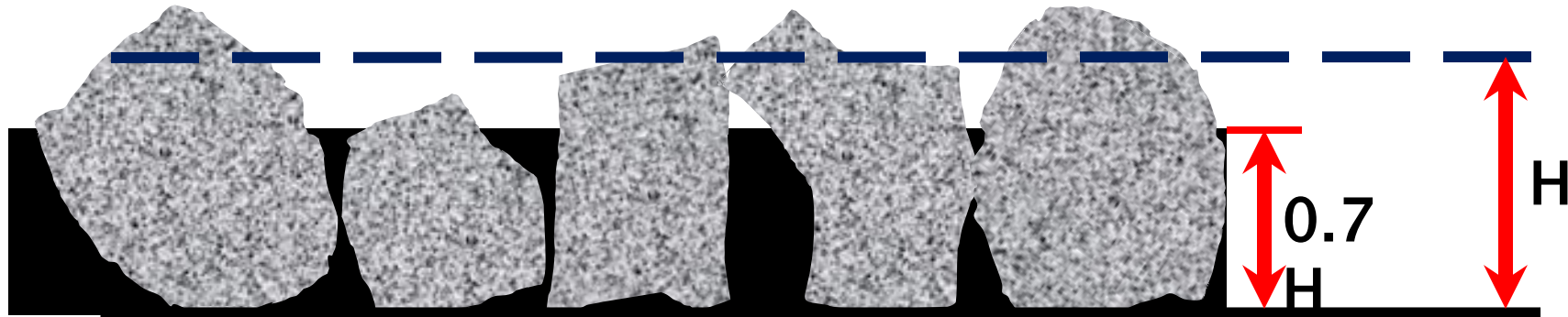

Embedment ($0.7 H$)

Aggregate Application

▶ Don't over apply

- Ideally, 1 stone thick
- Too much is as bad as not enough
- “Salt and Pepper” appearance

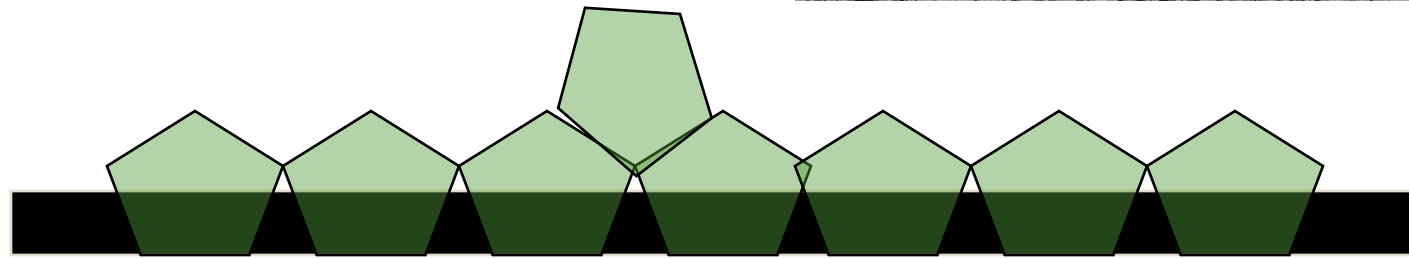

Inputs that affect Embedment

- ▶ **Materials**
 - Emulsions
 - Aggregates
- ▶ **Equipment**
 - Asphalt Distributor
 - Chip Spreader
 - Rollers
 - Brooms
- ▶ **Application**
- ▶ **Existing Pavement**



Equipment

Equipment Placement

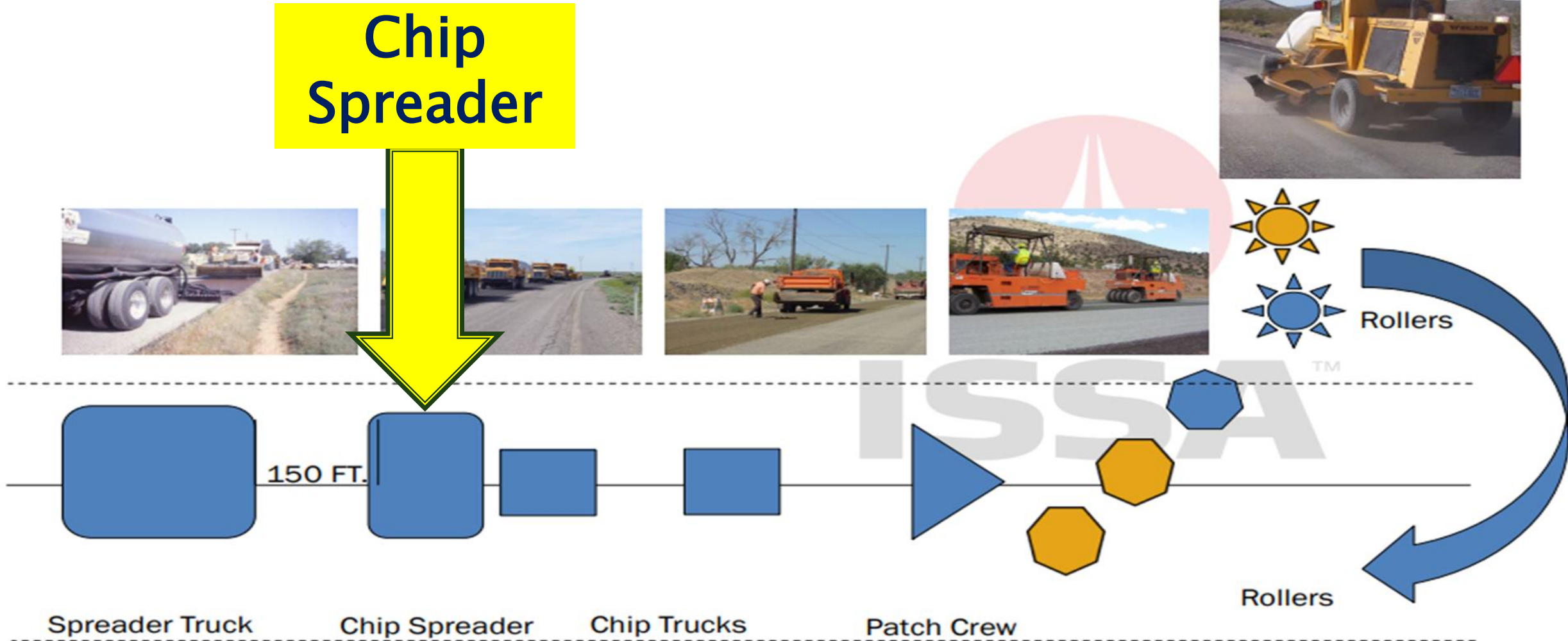

Equipment

Equipment Placement

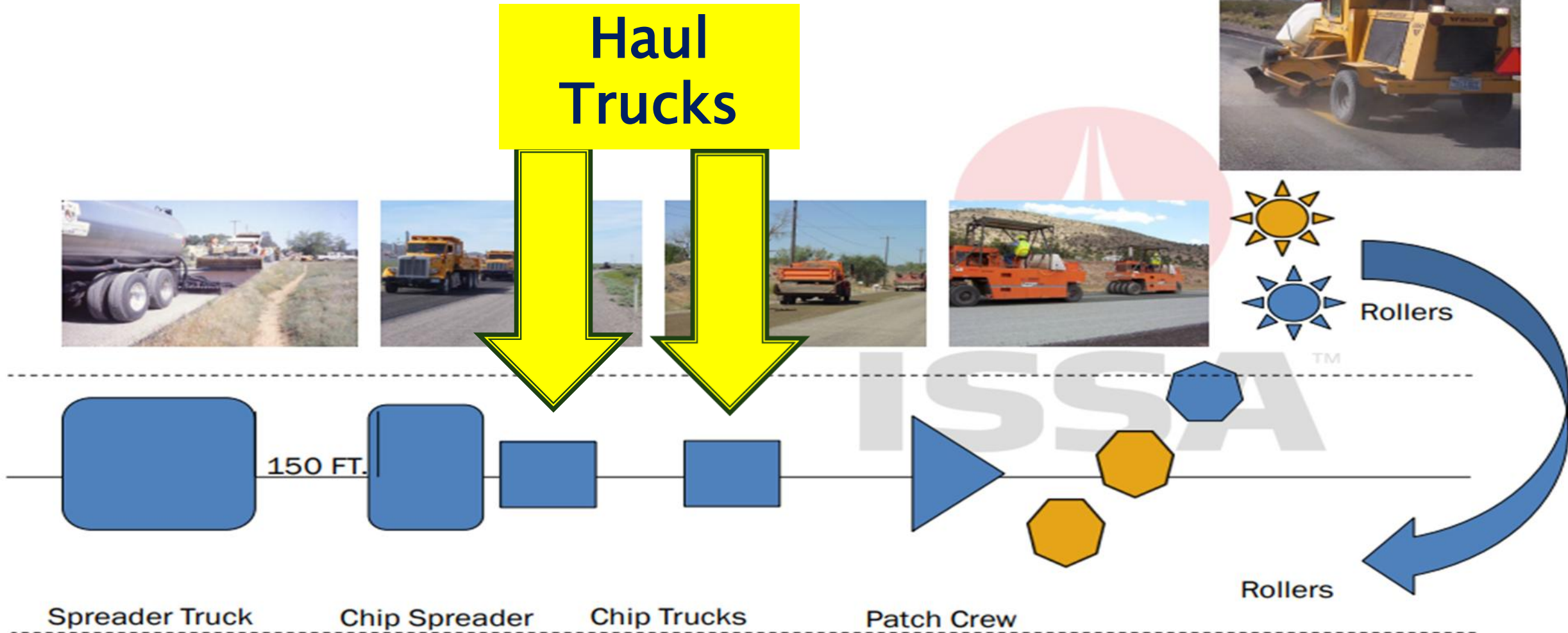

Haul Trucks Checklist

- ▶ Compatibility
- ▶ Dirty Tires cause “pick ups”
- ▶ **No sharp turns**
- ▶ Enough trucks to do the job
- ▶ No Leaks
- ▶ **Stagger wheel paths**
- ▶ Chip Bar and Tailgate latch required.
- ▶ **Watch the Air Tank Bleed Valve. Can damage seal if directed straight down.**



Check each truck for hitch acceptance!



Stockpile and Loader Checklist

- ▶ Loader must be leak free
- ▶ Stockpile must be clean and stable to avoid contamination of aggregate.
- ▶ Stockpiles free draining avoid water entrapment
- ▶ **Minimal handling will help reduce degradation.**



Equipment

Equipment Placement

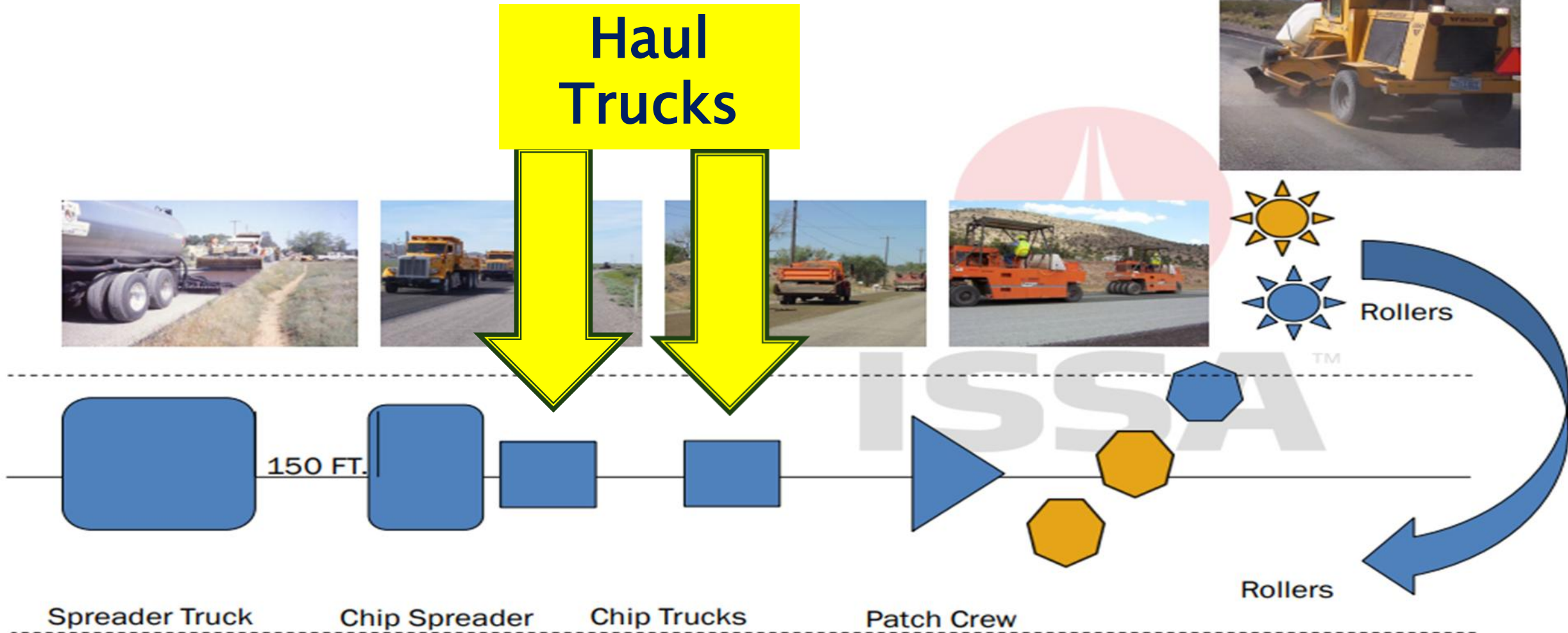

Equipment

Equipment Placement

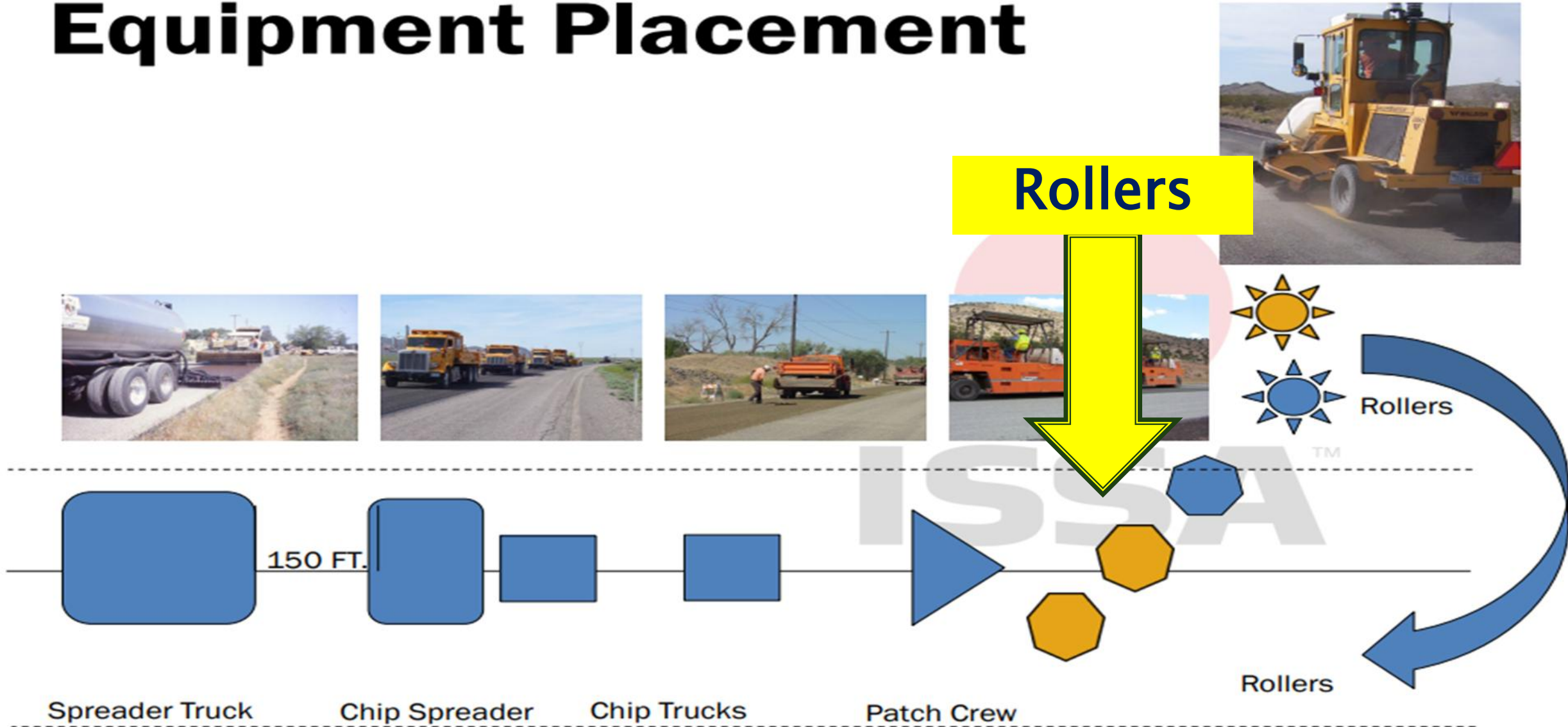

ISSA

TM

Rolling



The first rollers -- the trucks!

Rolling

- ▶ Immediately after chipping
 - Orients chips on their flat side
- ▶ Two Pneumatic Rollers
- ▶ 5 ton minimum
- ▶ Stop after set
- ▶ Moderate speed
- ▶ **Stagger rollers**



Roller Checklist

- ▶ Nine Wheel Pneumatic Rollers
- ▶ Minimum two rollers, **three is best**
- ▶ Orients aggregate on flattest side.
- ▶ Embeds aggregate in binder
- ▶ Achieves mechanical lock of aggregate particles
- ▶ 8 ton minimum
- ▶ Tire Pressure
 - 85 psi
 - No variance of more than 5 psi between all tires



Roller Checklist

Alabama Bituminous Surface Treatments 401

401.03 (a) 4. Rollers.

A self-propelled **steel wheel roller** having a weight {mass} between 5 tons {4 metric tons} and 8 tons {7 metric tons} shall be required immediately behind the aggregate spreader followed by a self-propelled pneumatic tired roller. Only one coverage shall be made with the **steel wheel roller.**

Roller Checklist

Alabama Scrub Seal Section 433

433.03 (e) 4. Rollers.

Two pneumatic tire rollers shall be used to seat the aggregate into the emulsion. The rollers shall be self-propelled. The minimum total weight of each roller shall be 5 tons.

433.03(f) Material Application.

The seal should be rolled immediately after the aggregate is applied. There shall be at least three passes made with a pneumatic roller.

Roller Checklist

Alabama Scrub Seal Section 433

433.03 (e) 4. Rollers.

Two pneumatic tire rollers shall be used to seat the aggregate into the emulsion. The rollers shall be self-propelled. The minimum total weight of each roller shall be 5 tons.

433.03(f) Material Application.

The seal should be rolled immediately after the aggregate is applied. There shall be at least three passes made with a pneumatic roller.

Roller Checklist Construction

► Rollers

- At least 3 passes (“Applications”)
- 2 Roller Pattern
- 3 Roller Pattern

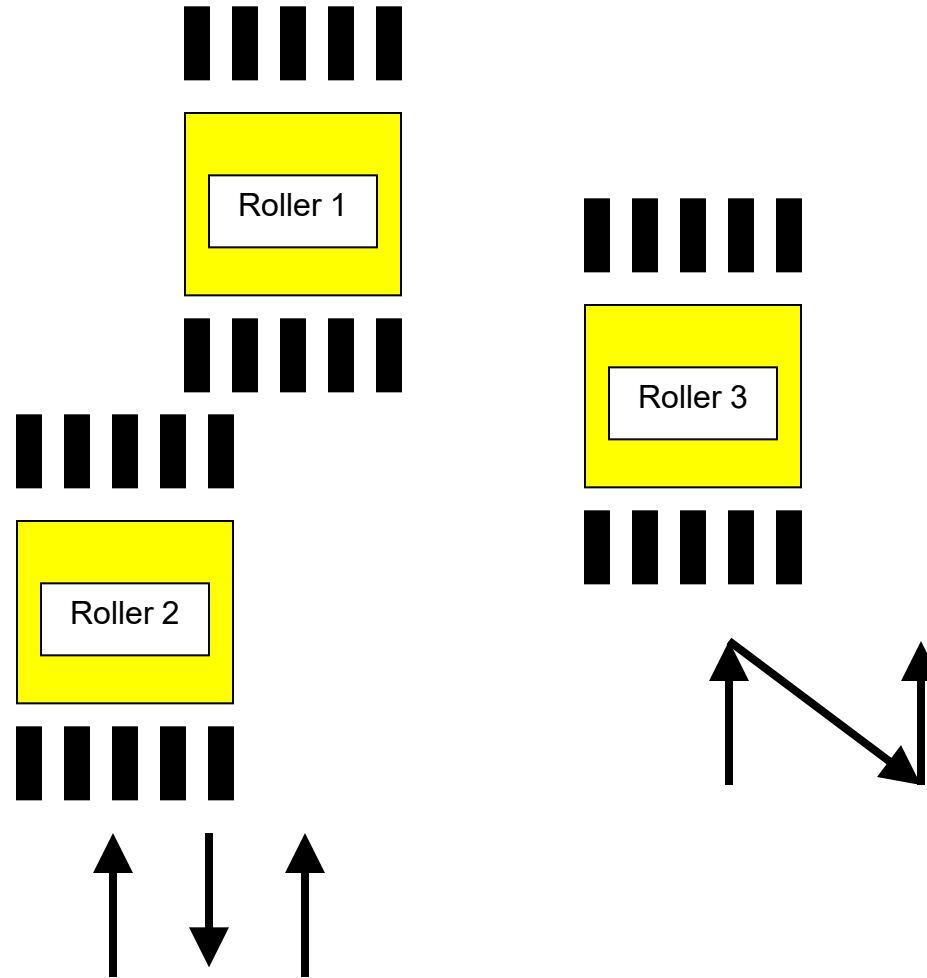

Roller Checklist

2 Roller Preferred Pattern

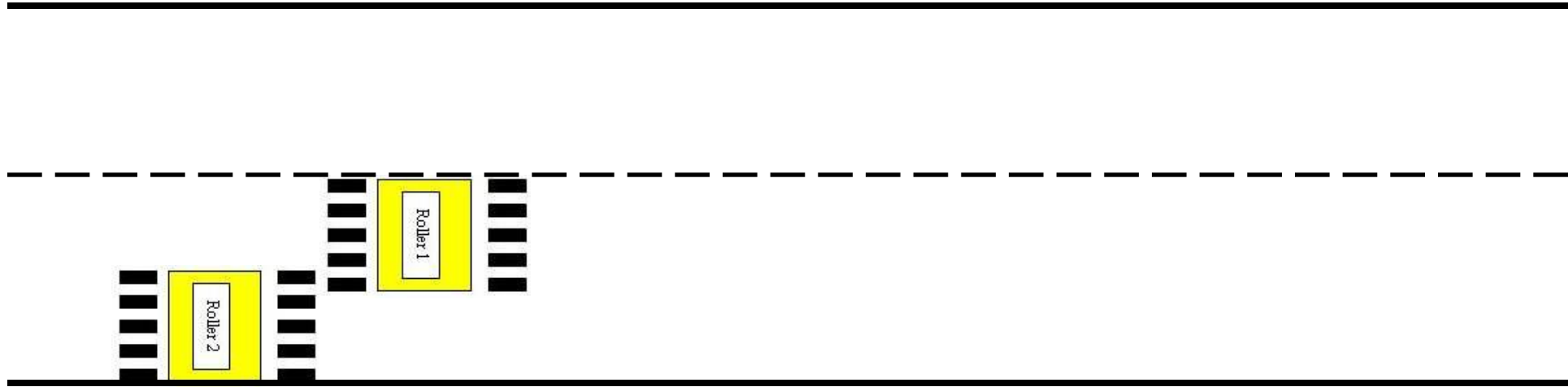

Both rollers stay in line

Roller Checklist

3 Roller Preferred Pattern

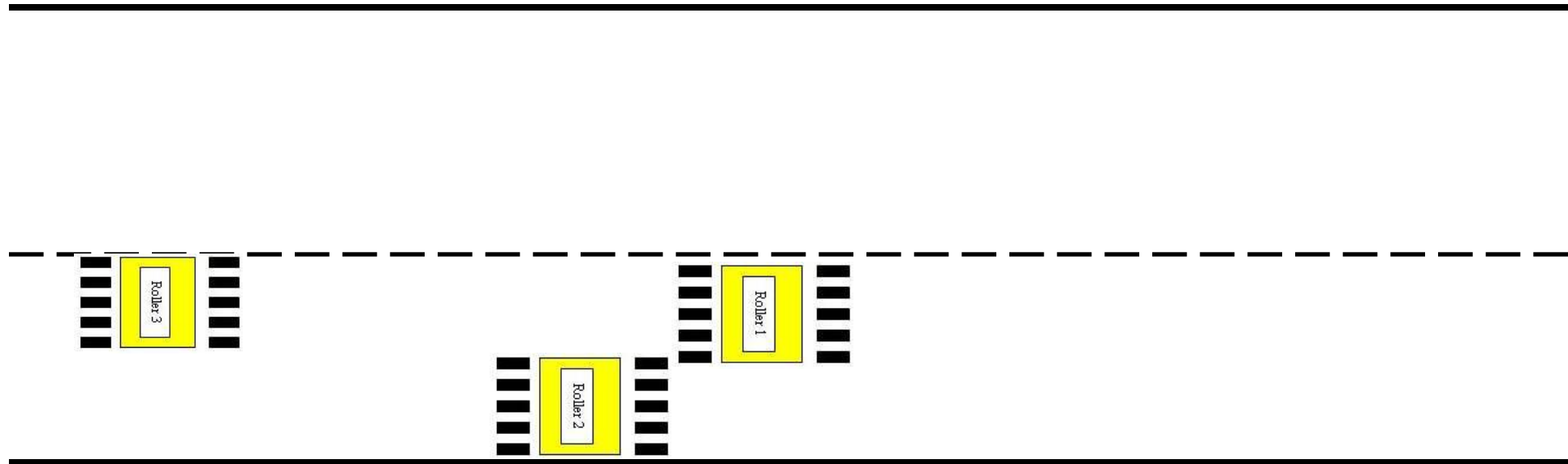

**Rollers 1 and 2 stay in line (same as 2 roller pattern),
Roller 3 zigzags**

Roller Checklist

Application Checklist

- ▶ Enough rollers available to make three passes while keeping up with the Chip Spreader without exceeding 3 – mph.
- ▶ Watch for rooster tails of dislodged aggregate for fast rolling.
- ▶ Rollers limit turning and stopping on fresh seal.
- ▶ Keep tires clear of emulsion.



Roller Checklist Construction

Food For Thought---Mississippi spec's

907-410.03.3.6—*Application of Cover Coat Mat'l.*

- The entire application of aggregate shall be rolled as soon as possible after application.
- Rolling shall be continued and repeated as often as necessary to key the cover material thoroughly into the bituminous material over the entire surface.
- Pneumatic rollers shall be used in the sequence that will provide the rolling pattern that results in the best adhesion of the aggregate to the bituminous material and the best surface qualities.
- In all cases there *shall be at least five complete coverages* of the entire surface of the treatment with a pneumatic-tire roller.

Alabama Equipment Calibration

Alabama Scrub Seal Section 433

433.03(f) Material Application.

- ▶ The aggregate shall be dry during spreading. The aggregate shall be evenly spread over the scrubbed emulsion.
- ▶ The seal should be rolled immediately after the aggregate is applied. There shall be at least three passes made with a pneumatic roller.
- ▶ The scrub seal system shall be stiff enough to allow removal of excess aggregate without damage to the pavement surface.
- ▶ The excess aggregate shall be removed with the vacuum broom within two hours of rolling or as directed by the Engineer.

Roller Checklist

Food For Thought---Mississippi spec's

907-410.03.3.6—Application of Cover Coat Mat'l.

- The entire application of aggregate shall be rolled as soon as possible after application.
- Rolling shall be continued and repeated as often as necessary to key the cover material thoroughly into the bituminous material over the entire surface.
- Pneumatic rollers shall be used in the sequence that will provide the rolling pattern that results in the best adhesion of the aggregate to the bituminous material and the best surface qualities.
- In all cases there shall be at least five complete coverages of the entire surface of the treatment with a pneumatic-tire roller.

Equipment

Equipment Placement

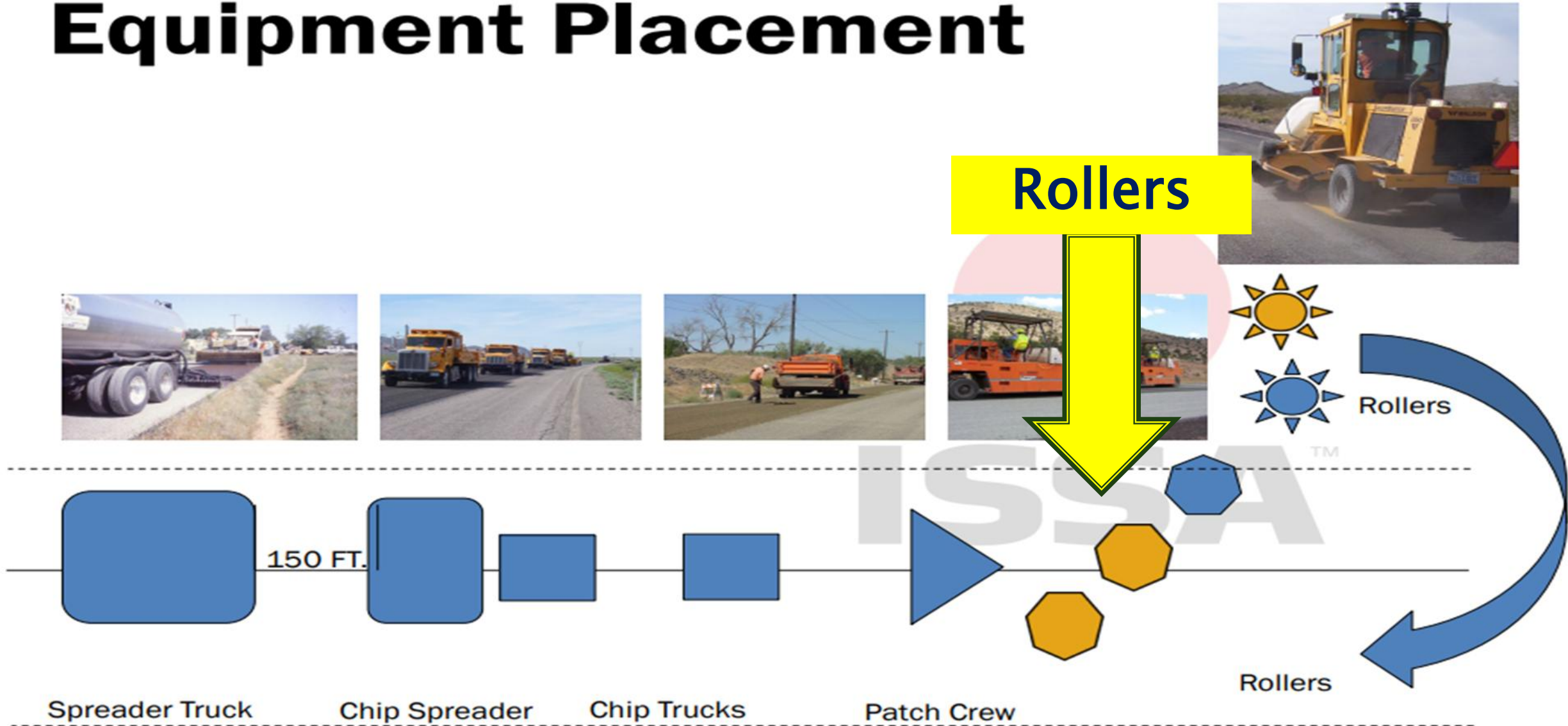

Equipment

Equipment Placement

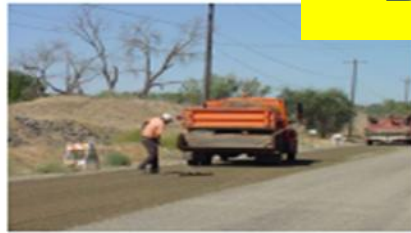

Brooms

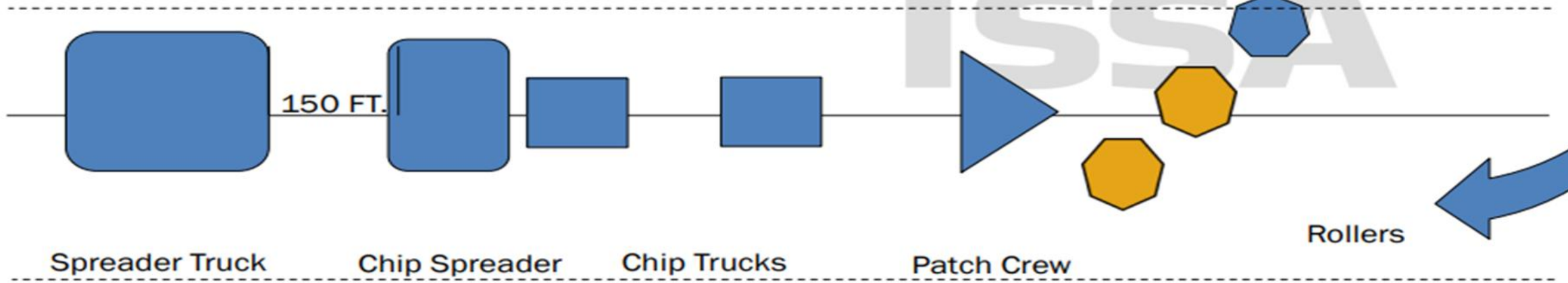
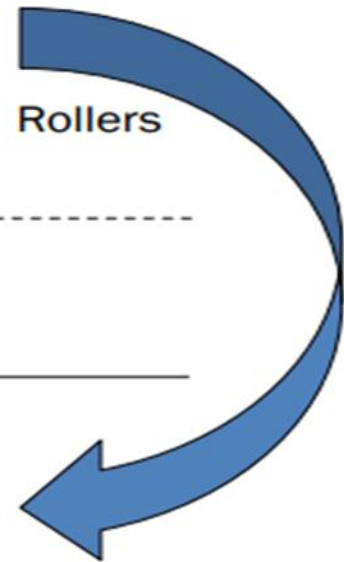

Equipment

Brooms & Checklist

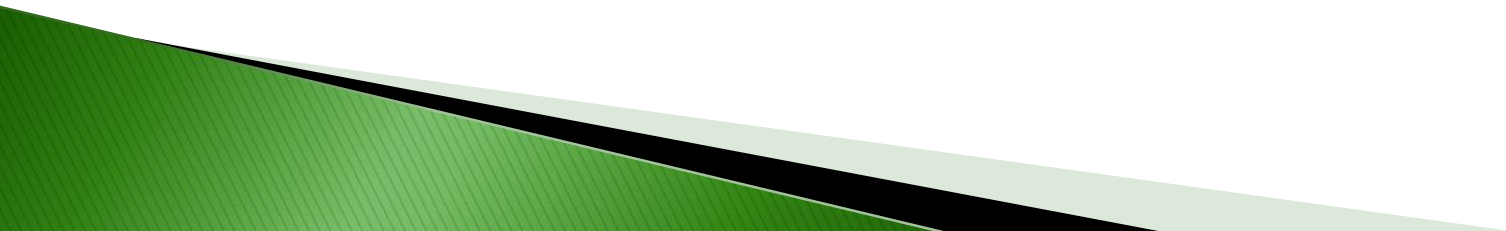

Equipment Brooms & Checklist



Brooms & Checklist

- ▶ Light brooming removes excess chips
- ▶ Time before brooming varies
 - Minimum of One Hour or LONGER
- ▶ **Excess chips can dislodge other chips**
- ▶ Can also damage windshields
- ▶ Joint may need to be broomed before next pass
- ▶ Next Morning Remove Loose Chips
 - Early Morning When Binder is Tougher

Brooms & Checklist



- ▶ Self propelled
- ▶ Four Wheels
- ▶ Watch Speed – Do No Harm
- ▶ **Plastic Bristles (Not Wire)**
- ▶ Cleans existing road surface and joints
- ▶ Used to remove excess aggregate when binder is fully cured.
- ▶ Water may be used for dust.
- ▶ Rotary / Vacuum / Pick up

Brooms & Checklist

- ▶ Brooming should start when emulsion is cured; usually between one and two hours after rolling.
- ▶ Light brooming only. Heavy brooming removes excess chips. Excess chips remove other chips and Embedment is lost.
- ▶ Broom centerline joint if necessary.
- ▶ Open to controlled rolling traffic as soon as safely possible



Traffic Control



Traffic Considerations

Alabama Bituminous Surface Treatments 401

401.04 Maintenance and Protection of Surface and Traffic.

- ▶ Maintenance shall include immediate repair of any failures or defects that occur, repeated as often as is necessary to keep the surface continuously intact and acceptable. Maintenance shall be performed without direct compensation.
- ▶ *Unless otherwise specified on the plans or in the proposal,* the Contractor shall handle traffic through the work and over the surface except while bituminous material is actually being applied and covered with aggregate. It shall be his responsibility to take whatever steps are necessary or directed to protect both the work and the traveling public.

Traffic Considerations

Alabama Scrub Seal Section 433

*No mention in 433 Specification or
Special Provision for **Control of
Traffic***

Traffic Considerations

Alabama Scrub Seal Section 433

433.3 (f) Material Application;

- ▶ The roadway shall not be opened to traffic until at least two hours after the completion of the placement of the emulsion and aggregate and the sweeping operation completed.
- ▶ The Engineer may require a second power sweeping to remove any loose aggregate. Excess aggregate shall be removed from the project unless otherwise approved by the Engineer.

Traffic Considerations

Ideally, keep traffic off until emulsion cures sufficiently to hold the aggregate.



Traffic Considerations

- ▶ Control traffic by:
 - Use of pilot vehicles
 - Pilot vehicle is the lead through the work zone
 - Close road
 - Advance notice signage, alternate route
 - Multilane roads – keep lane closed



Traffic Control

- ▶ Low speed (20 to 30 mph) traffic after rolling is completed. Open to traffic 1 to 3 hours depending on weather and traffic volumes
- ▶ Keep Traffic off fresh chip seal as long as possible
- ▶ **Never allow start/stop traffic or sharp turning traffic on newly completed chip seal**
- ▶ Pilot car recommended for traffic control
- ▶ Apply Pavement markings - 48 to 72 hours after chip seal application is completed

Traffic Considerations

Food For Thought---Mississippi spec's

907-410.03.7---Control of Traffic.

- ▶ Unless otherwise advised, the Contractor's operations shall be schedule such that all lanes of traffic are open to the traveling public at the end of each day.
- ▶ Considering time needed for curing and preparation prior to opening traffic, the Contractor *should not apply bituminous material two (2) hours before dusk,* or longer, to allow sufficient time for bonding of the aggregates.

Traffic Considerations

Food For Thought---Mississippi spec's

907-410.03.7---Control of Traffic.

- ▶ After the surface treatment has been rolled and the bituminous material has cured a minimum of one (1) hour, or longer if necessary to sufficiently hold the aggregate in place, the Contractor shall perform an initial brooming operation consisting of lightly sweeping excess aggregate material from the surface.
- ▶ *After the initial brooming has been completed, public traffic will be allowed on the roadway.*
- ▶ Immediately the next morning, a final brooming shall be performed to remove any remaining excess aggregate material from the previous day's seal operation.

Alabama Chip Seal Payment Method :

401.06 Basis of Payment. (a) Unit Price Coverage. Payment for accepted bituminous surface treatment, or bituminous surface treatment with polymer additive, Pay Item No. 401-B, measured as provided above, will be paid for at the **contract unit price per square yard** {square meter} **complete in place** for the type of bituminous treatment specified in the proposal by the type designation letter or letters; except that adjustments in the contract unit price shall be made as follows: When changes in amounts of treatment materials are ordered as provided in Article 401.01



Alabama Scrub Seal Payment Method

433.04 Method of Measurement.

Scrub seal will be measured in units of square yards.



Trouble Shooting



Trouble Shooting



Distributor

Where is the chip spreader?

Liquid is already breaking "brown to black"

Trouble Shooting

Loss of Cover Aggregate

- ▶ Dirty aggregate
- ▶ Insufficient asphalt
- ▶ Chips spread too late
- ▶ Unequal spray bar distribution
- ▶ Too Much Aggregate



Trouble Shooting

Bleeding / Flushing



- Over-application of binder
- Dense graded screenings
- Pre-existing rutting



Trouble Shooting

Stripping / Drilling



- ▶ Too little binder applied
- ▶ Dirty aggregate
- ▶ Poor weather
- ▶ Poor rolling
- ▶ Cold binder or high viscosity

Trouble Shooting

Improper Broom Maintenance

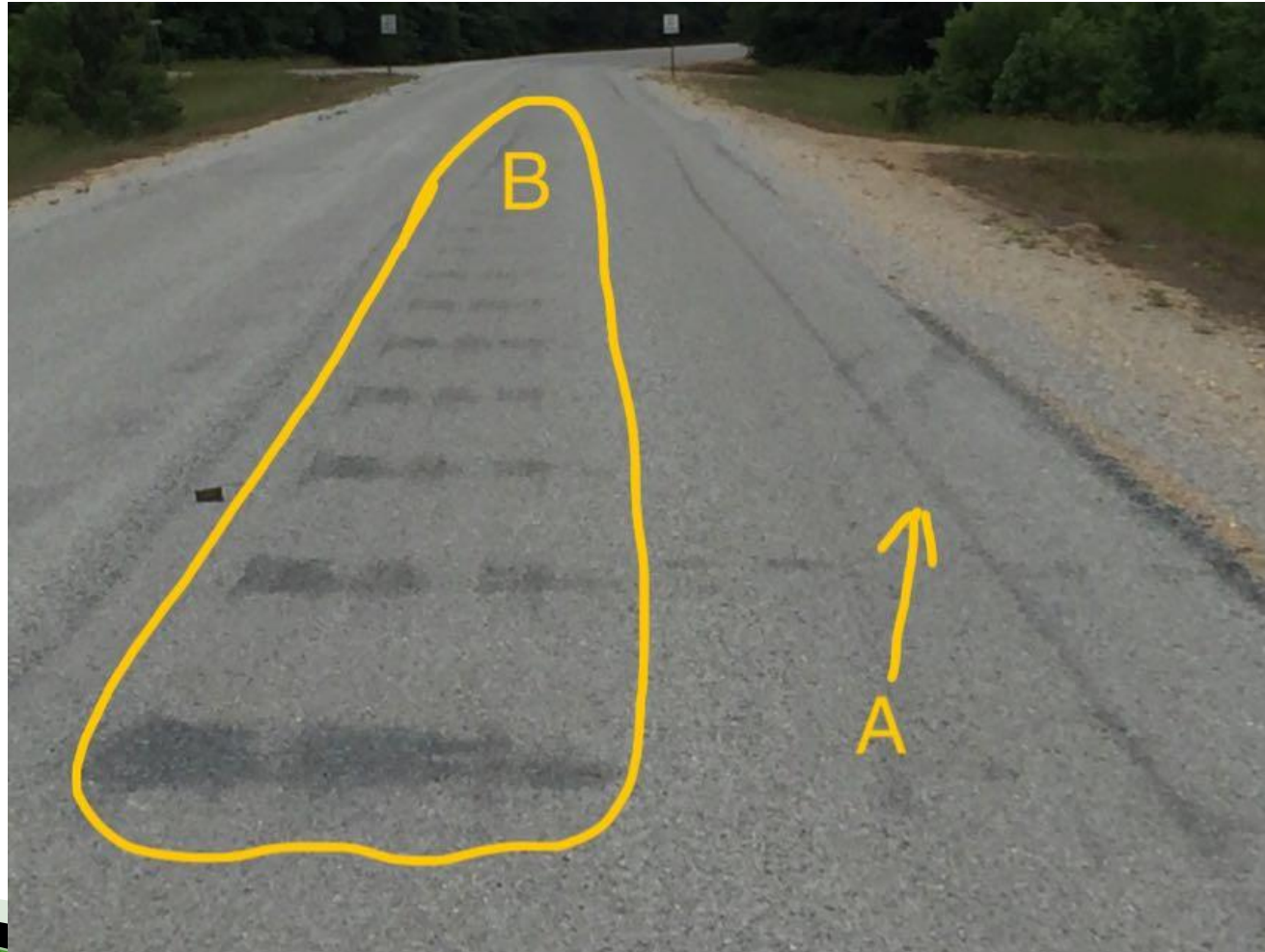

Trouble Shooting

Improper Broom Maintenance

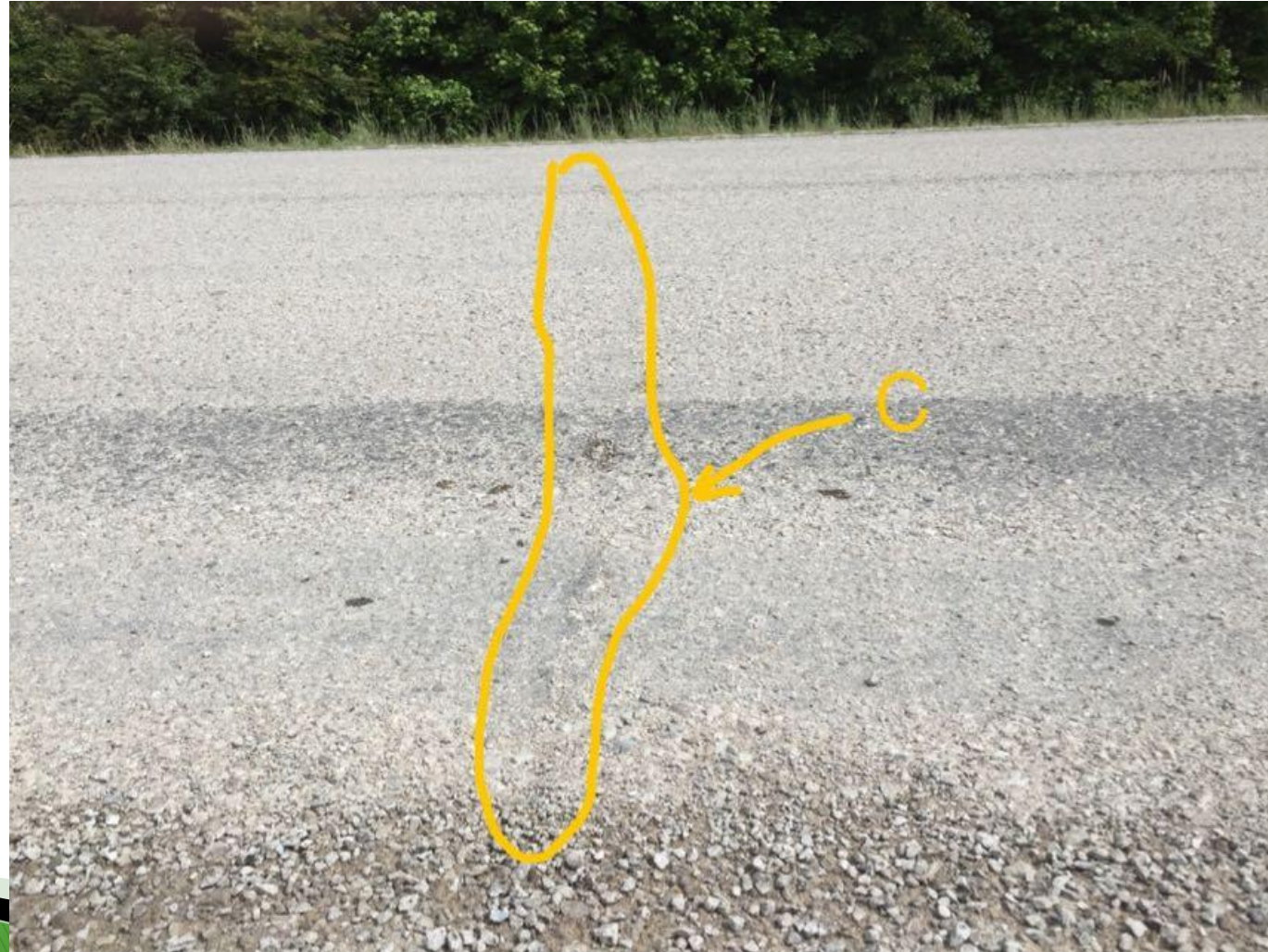

Trouble Shooting

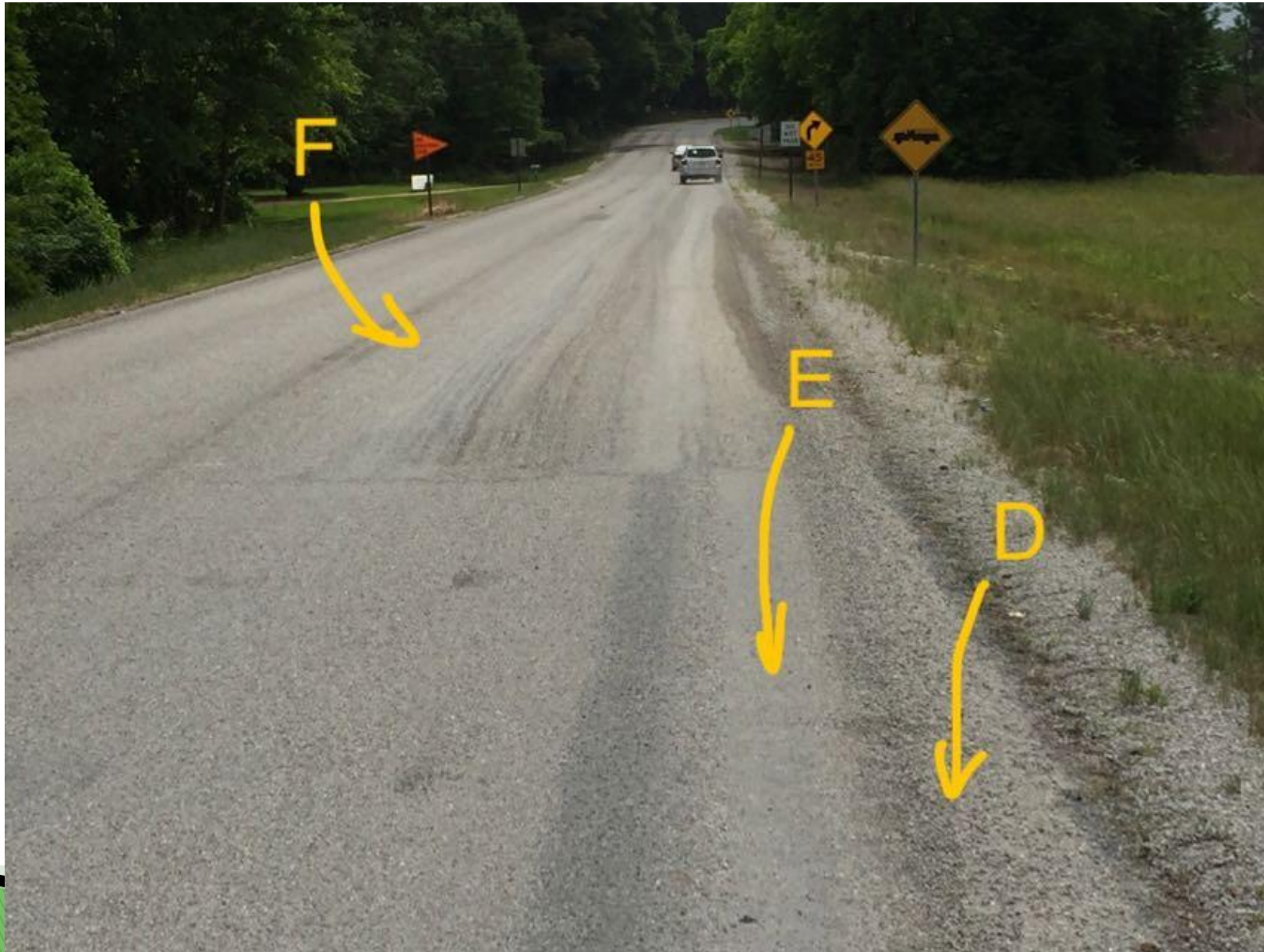

Trouble Shooting

Changing Conditions

- ▶ Patches
- ▶ Rutting
- ▶ Surface Texture Changes



What's wrong with this picture?



What's wrong with this picture?



Final Thoughts

- ▶ Remember, Embedment of the stone is key!
- ▶ Everything you do should be aimed at achieving proper embedment and minimum stone loss.

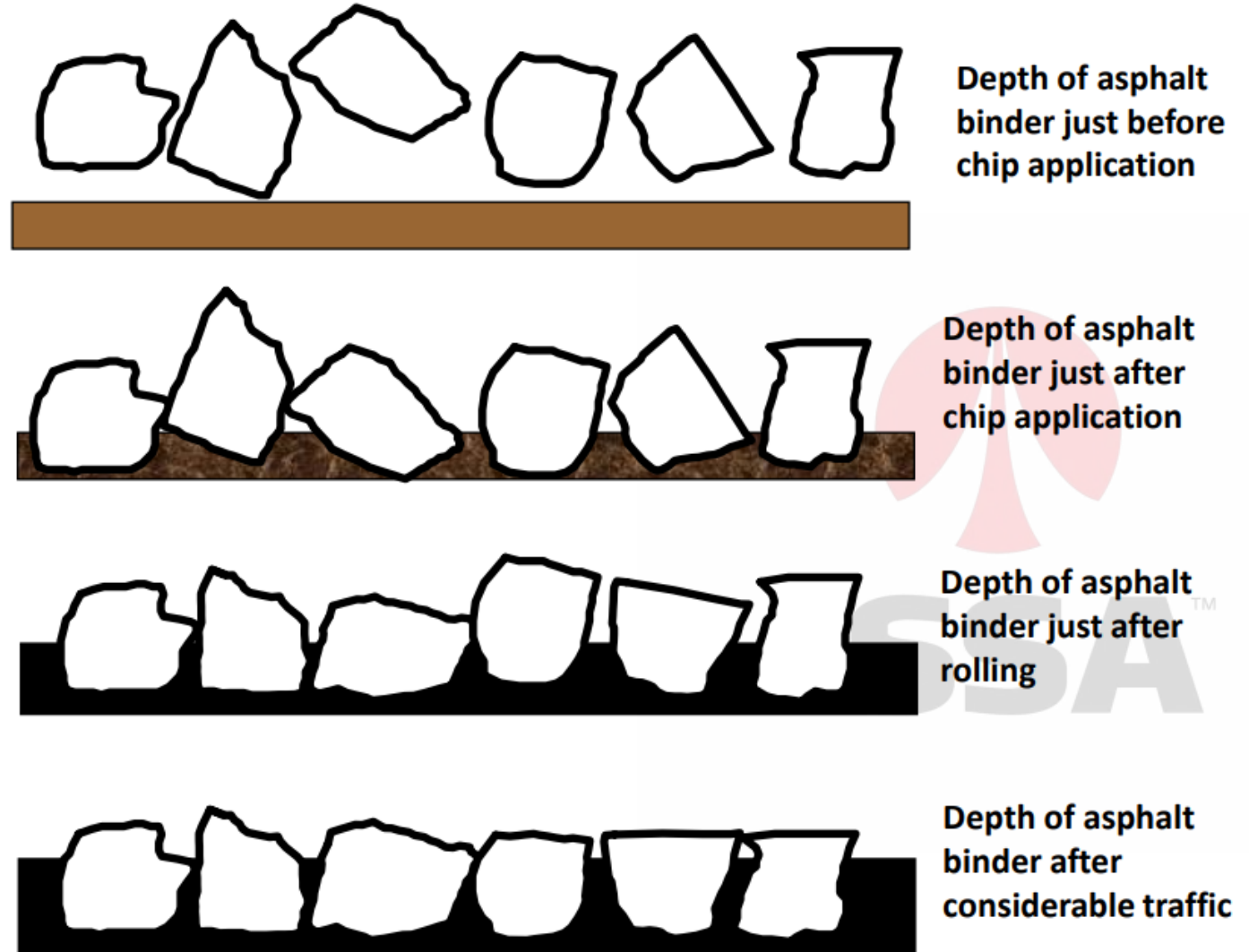

Questions?

